

Part Number:
1990220

Models:
Himalayan (Accessory Aluminium Handlebar)

WARNING: Royal Enfield genuine accessories are designed to fit only the specific Royal Enfield motorcycle(s) that are specified above. They should not be fitted to any other type of motorcycle. Pay particular attention to the warnings and cautions contained in this instruction, failure to do so may result in an incorrect installation of the accessory which could result in an unsafe riding condition and possible accident. If in any doubt always seek the help from your authorised Royal Enfield dealer.

WARNING: Before starting any accessory kit installation ensure the motorcycle is supported in a stable condition. Failure to support the motorcycle correctly could lead to motorcycle damage or personal injury.

WARNING: All fixings must be tightened to the torque values specified in this instruction. Failure to tighten fixings to the correct torque could result in an unsafe riding condition and possible accident.

NOTE: The content of this instruction is subject to change at any time without notice or liability. Royal Enfield reserves the right to revise the information presented at any time.

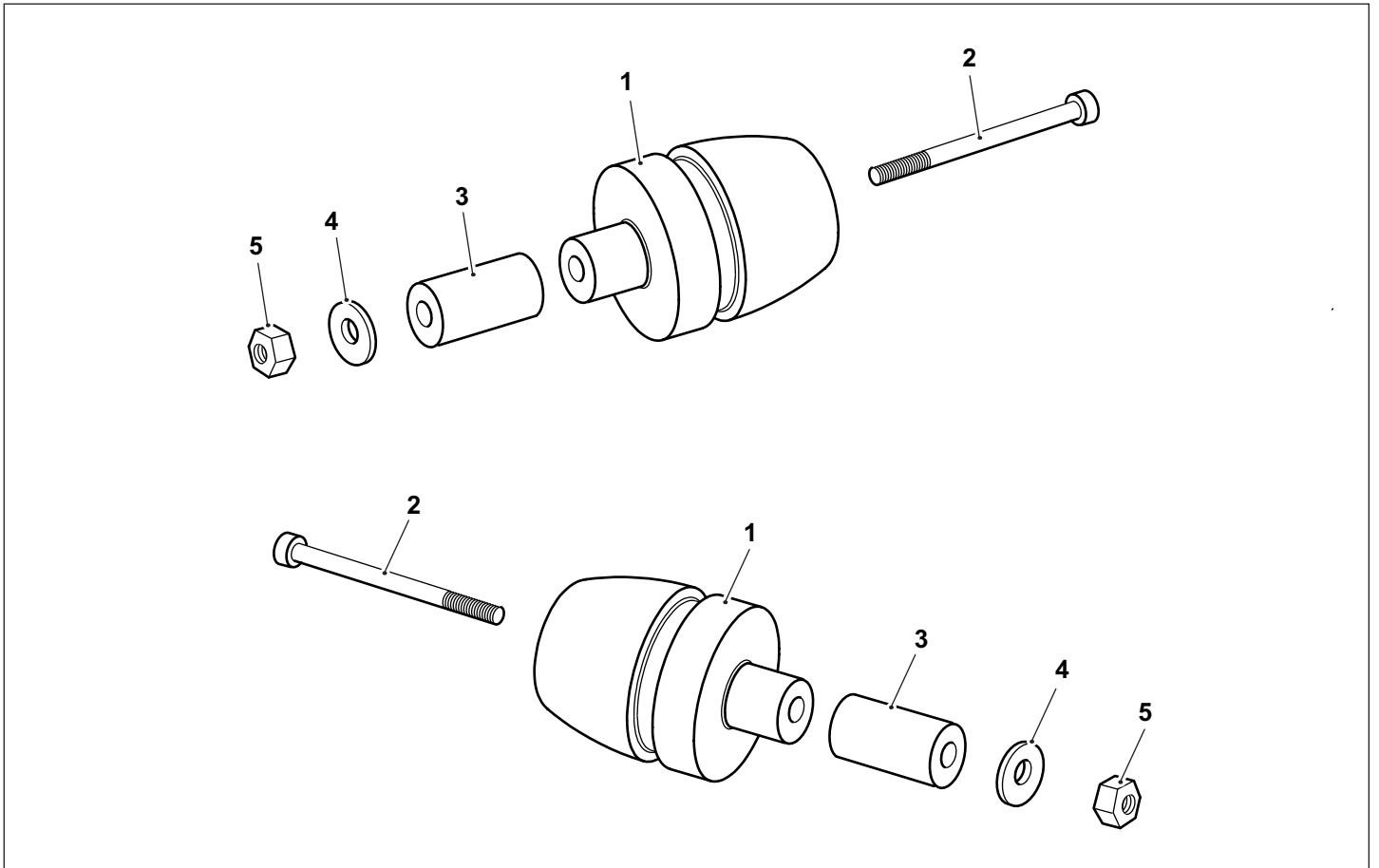

Item	Description	Qty
1	Bar end weight	2
2	Fixing, M6 x 80mm	2
3	Rubber bush	2
4	Washer	2
5	Nut, M6	2

1 Remove the plastic end cap (1) from the handlebars on the left hand side of the motorcycle. Retain the plastic end cap (1) for reuse if the accessory bar end weights are to be removed.

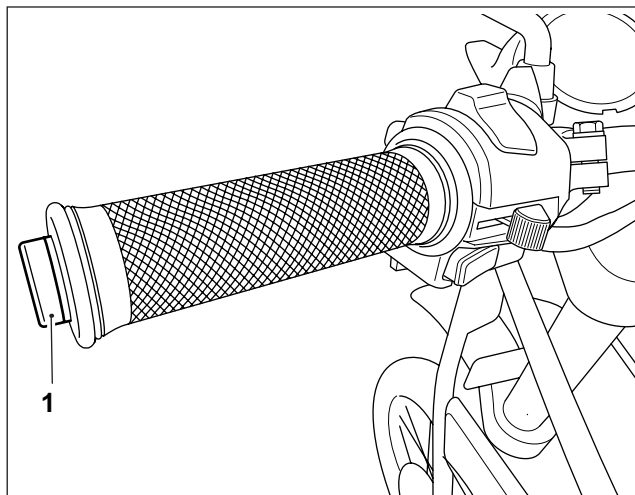

2 Collect one of the bar end weights (1), M6 x 80mm fixings (2), rubber bushes (3), washers (4) and M6 nuts (5) from the kit. Assemble the components as shown and hand tighten the nut to position the washer against the rubber bush.

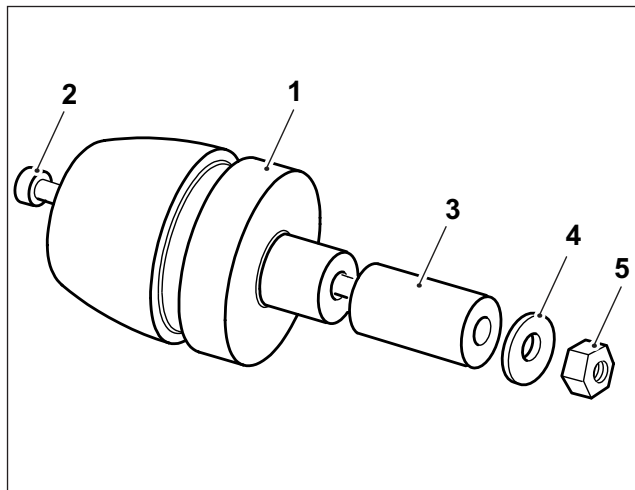

3 The nut (1) should now be tightened just enough to secure the washer (2) against the rubber bush (3), with a small amount of deforming of the rubber bush, as shown.

CAUTION: If the nut (1) is overtightened causing the washer (2) to deform the rubber bush (3) too much it will prevent the fitment of the bar weight assembly, likewise, if the nut (1) is not tightened enough the bolt (4) will not tighten adequately when the bar end weight assembly is fitted in to the handlebar.

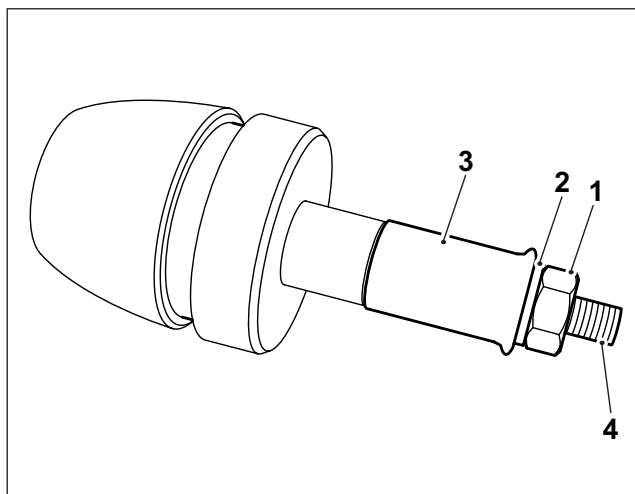

3 Fit the bar end weight assembly (1) into the left hand side of the handlebar (2) as shown. Push the bar end weight assembly fully in to the handlebar until the rear face of the bar end weight contacts the handlebar.

Tighten the bar end weight fixing (3) to **7Nm**.

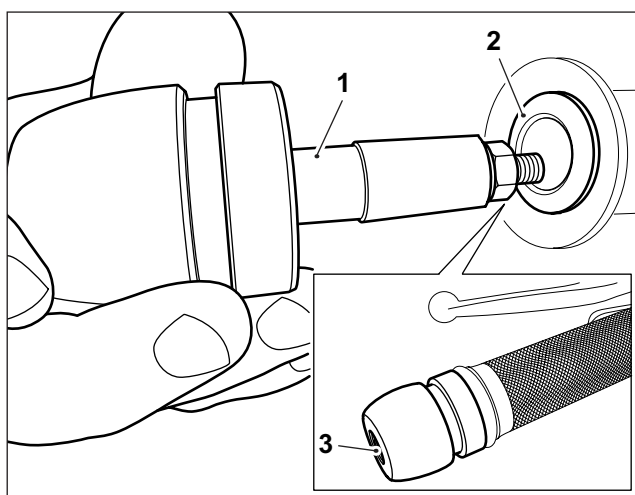

4 Repeat steps 1 to 3 for the right hand side of the motorcycle.

! **WARNING:** Ensure that the operation of the twist grip is smooth, without tightness and will return to the throttle closed position when released. A tight or sticking twist grip can lead to loss of motorcycle control and an accident.

5 Ensure both bar end weights are fitted securely and do not move in the handlebar.

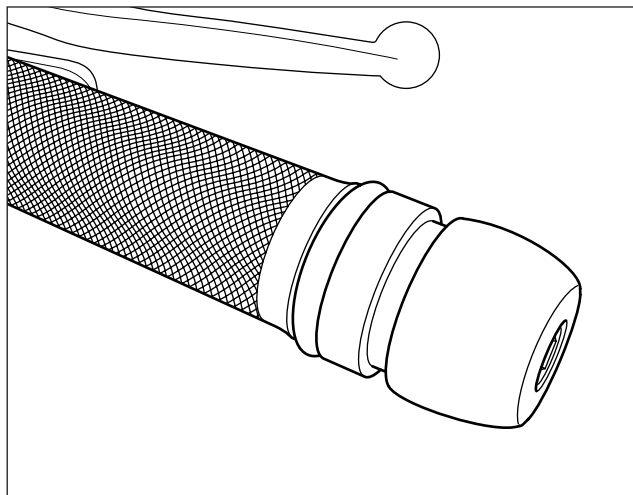

! **WARNING:** After fitting any genuine Royal Enfield accessory always ride the motorcycle with caution and allow time to become familiar with any change in the motorcycle handling characteristics. Failure to become familiar with any change in the motorcycle handling characteristics may cause the motorcycle to become unstable and result in an accident.