

Part Number:

1990413 - Flyscreen Short

1990414 - Flyscreen Tall

Models :

Continental (2018 onwards)

Interceptor (2018 onwards)

 **WARNING:** Royal Enfield genuine accessories are designed to fit only the specific Royal Enfield motorcycle(s) that are specified above. They should not be fitted to any other type of motorcycle. Pay particular attention to the warnings and cautions contained in this instruction, failure to do so may result in an incorrect installation of the accessory which could result in an unsafe riding condition and possible accident. If in any doubt always seek the help from your authorised Royal Enfield dealer.

 **WARNING:** Before starting any accessory kit installation ensure the motorcycle is supported in a stable condition. Failure to support the motorcycle correctly could lead to motorcycle damage or personal injury.

 **WARNING:** All fixings must be tightened to the torque values specified in this instruction. Failure to tighten fixings to the correct torque could result in an unsafe riding condition and possible accident.

 **CAUTION:** Care should be taken when fitting any accessory kit. Incorrect handling kit components or the use of incorrect tools could lead to component or motorcycle damage.

NOTE: The content of this instruction is subject to change at any time without notice or liability. Royal Enfield reserves the right to revise the information presented at any time.

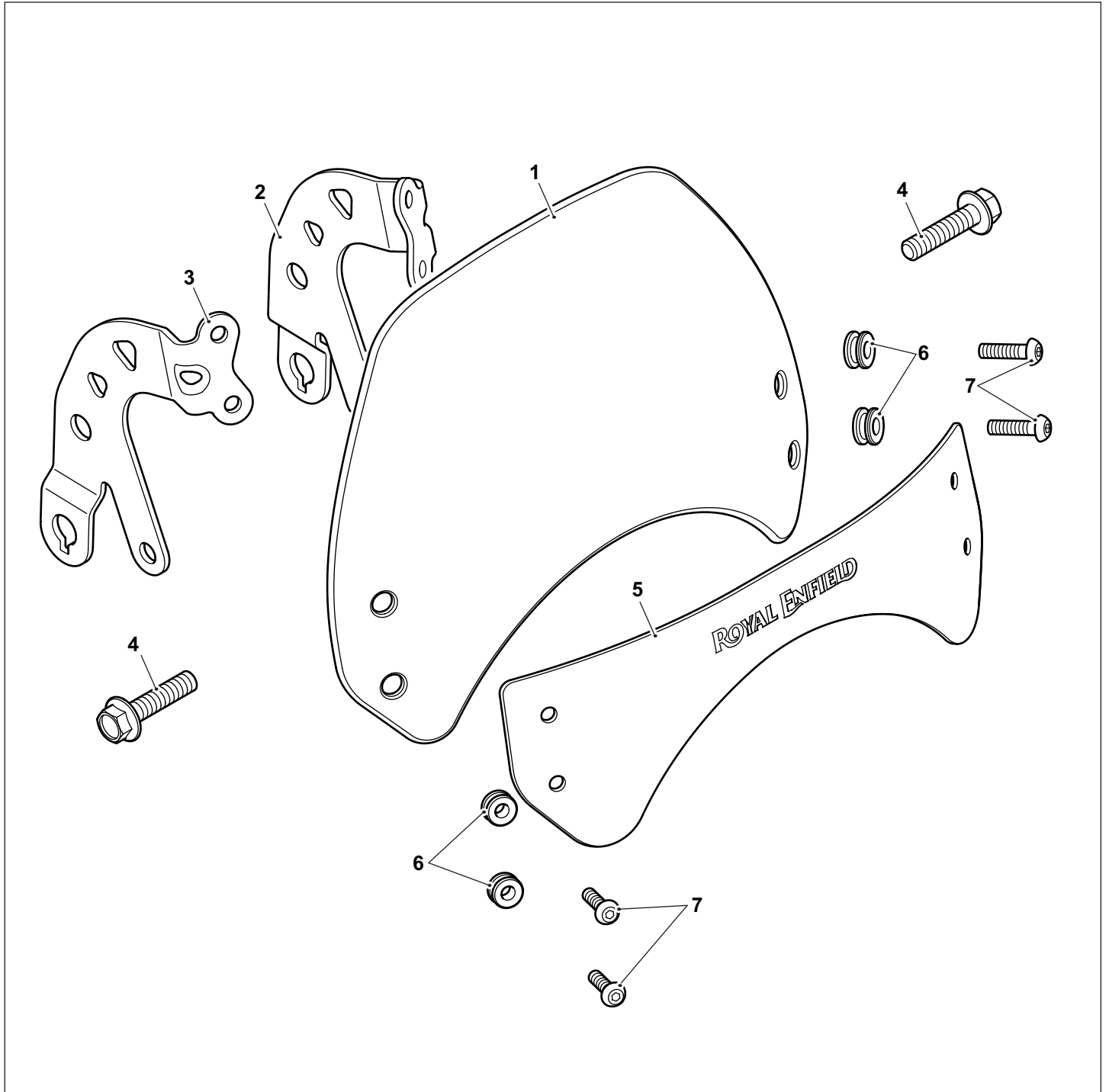

Item	Description	Qty
1	Flyscreen	1
2	Mounting bracket, Left hand	1
3	Mounting bracket, right hand	1
4	Fixing, M8 x 35mm	2
5	Embellisher	1
6	Grommet	4
7	Fixing, M5 x 20mm	4

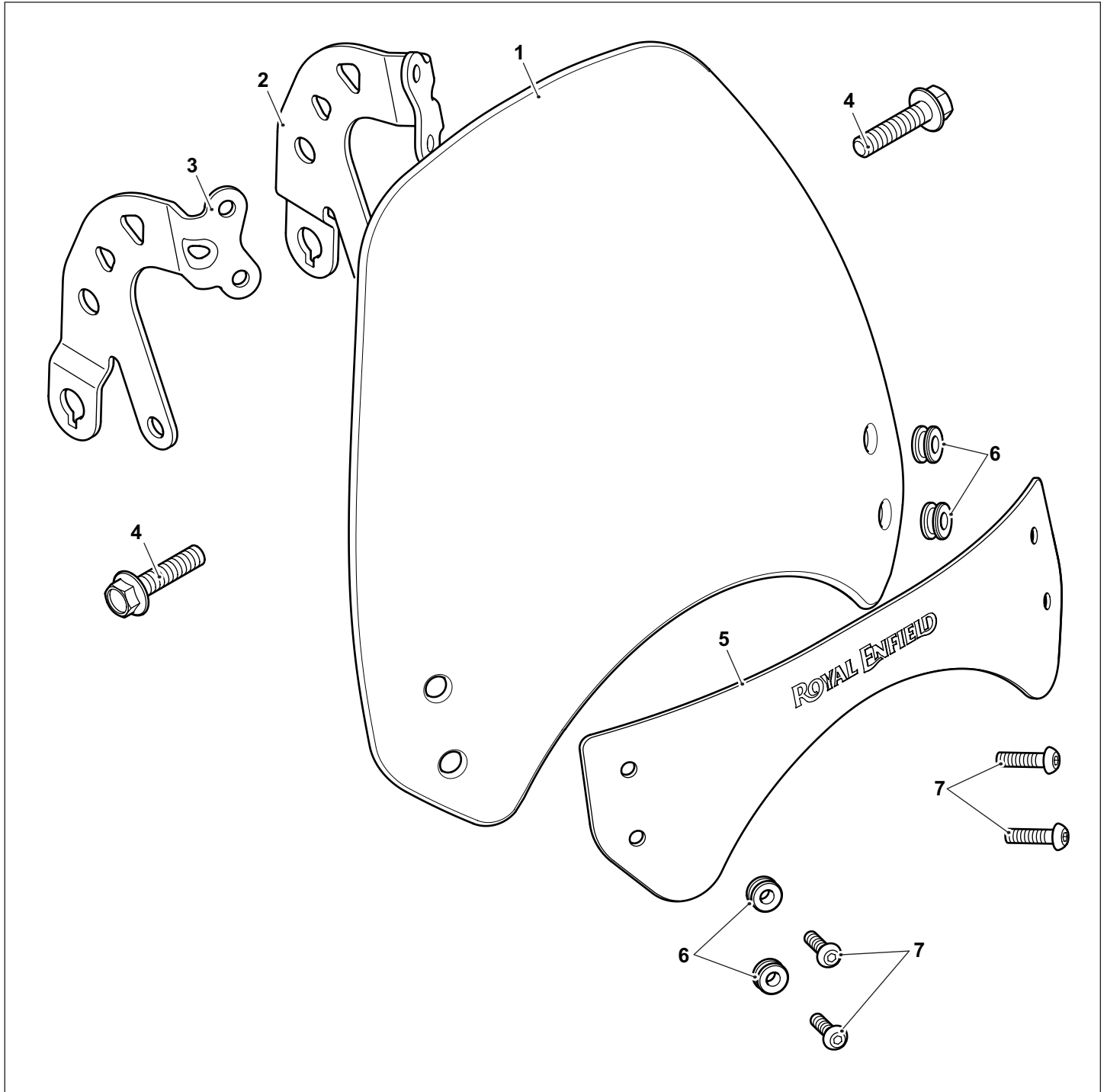

Item	Description	Qty
1	Flyscreen	1
2	Mounting bracket, Left hand	1
3	Mounting bracket, right hand	1
4	Fixing, M8 x 35mm	2
5	Embellisher	1
6	Grommet	4
7	Fixing, M5 x 20mm	4

1 Insert the ignition key (1) into the lock (2) in the side panel (3) on the right hand side of the motorcycle. Turn the key in a clockwise direction to release the side panel and carefully pull the bottom of the side panel outwards.

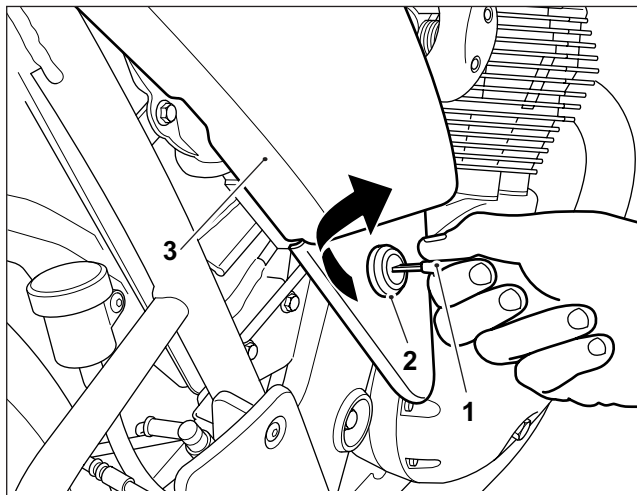

2 Remove the top of the side panel (1) from the retaining pegs (2) on the motorcycle frame. Ensure the grommets (3) remain correctly located in the side panel. Retain the side panel for reuse.

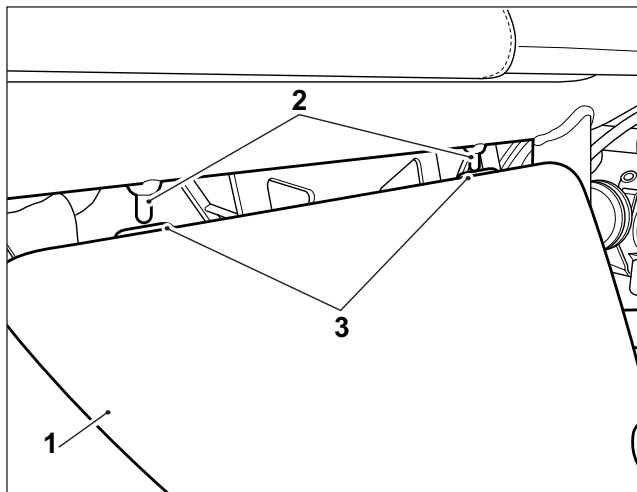

3 Pull the seat latch release cable handle (1), as shown, to unlatch the seat.

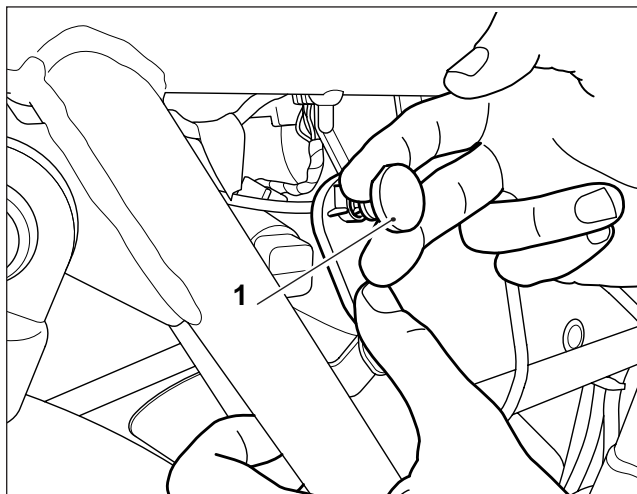

4 Lift the seat clear from the motorcycle. Retain the seat for reuse.

5 Disconnect the battery, negative lead first.

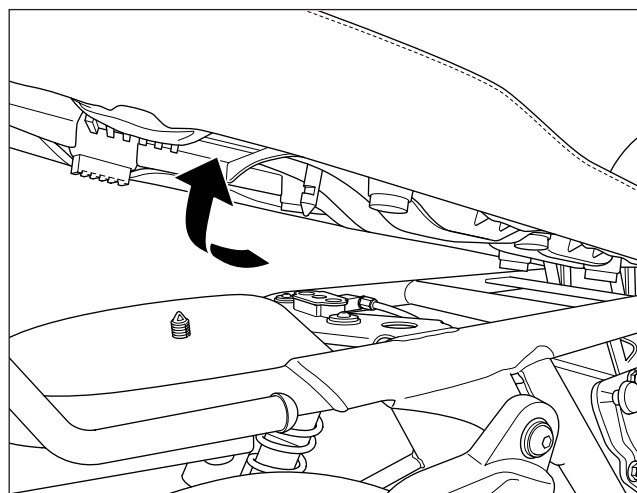

6 Loosen the fixing (1) at the top of the headlight bowl (2) to release the headlight bezel (3). Do not remove the fixing.

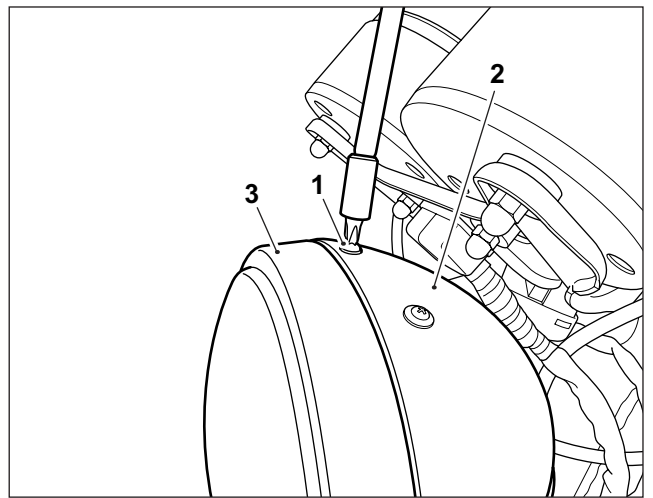

7 Detach the headlight assembly (1) from the headlight bowl (2) and move the top of the headlight assembly clear of the retaining clip (3).

Support the headlight assembly ensuring it is not allowed to hang from the wiring harness.

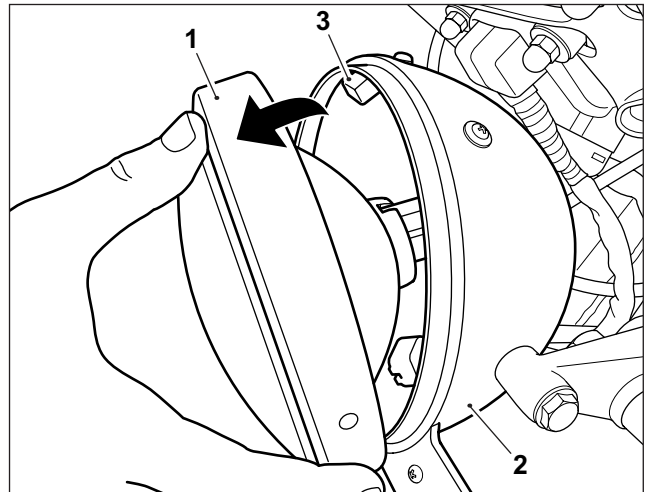

8 Disconnect the left hand (Black) (1) and right hand (white) (2) indicator harness connectors from the main wiring harness.

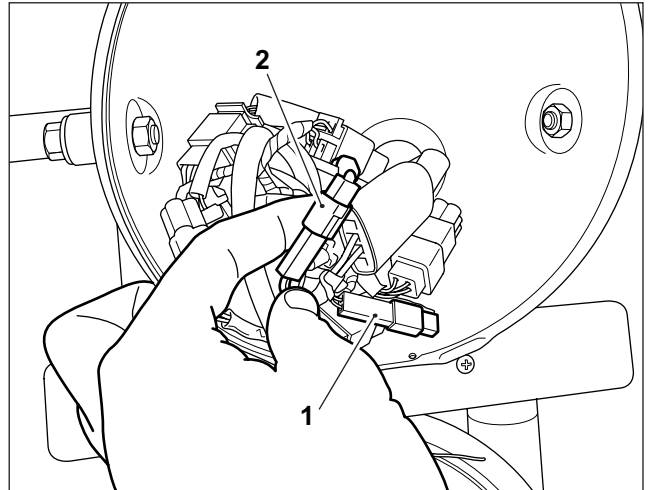

9 Remove the left hand indicator retaining nut (1) and washer (2). Retain the nut and washer for reuse.

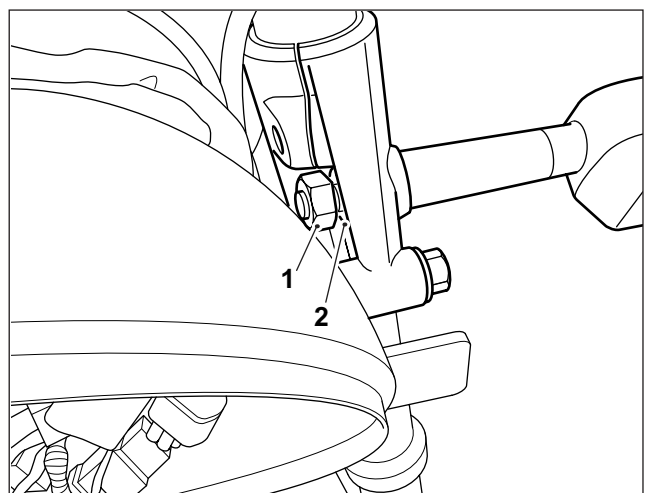

10 Remove the left hand indicator and indicator harness (1). Retain the indicator for reuse.

Note the routing of the indicator harness into the headlight bowl to help reassembly.

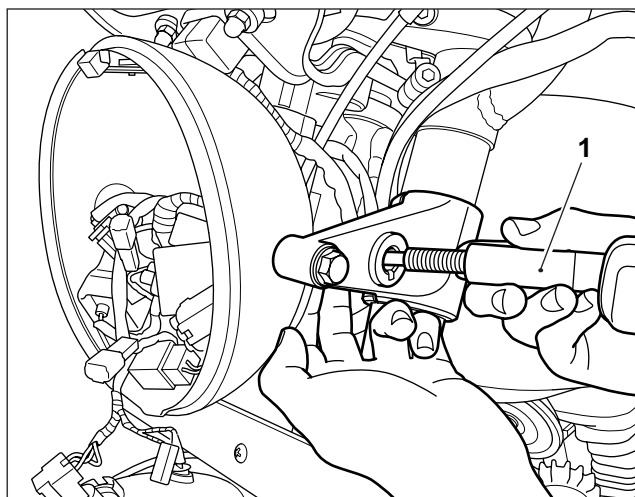

11 Remove the headlight bowl fixing (1) on the left hand side only. Retain the fixing for reuse if the flyscreen is removed.

WARNING: Remove only the left hand side headlight bowl fixing (1). Do not remove, or loosen, the right hand side headlight bowl fixing at this stage to ensure the factory headlight beam alignment is maintained.

If you suspect the factory headlight beam alignment has been compromised during the flyscreen installation please contact your local dealer.

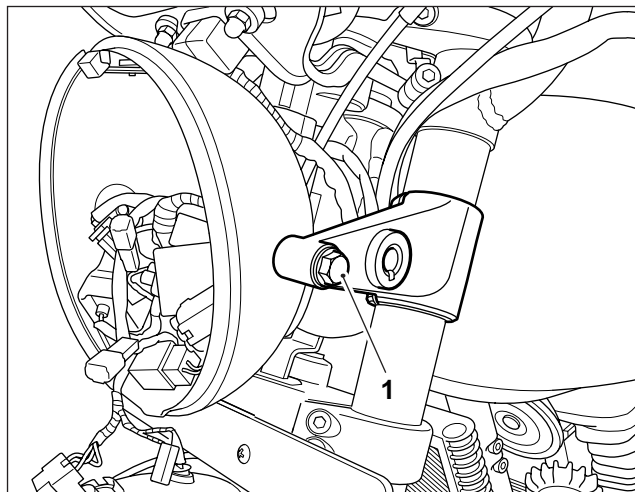

12 Position the left hand mounting bracket (1) from the kit on to the headlight bowl mounting (2) in the orientation shown. Align the bracket fixing positions with the headlight bowl and indicator fixing positions, as shown.

Fit an M8 x 35mm fixing (3) from the kit to retain the mounting bracket and headlight bowl. Do not fully tighten the fixing at this stage.

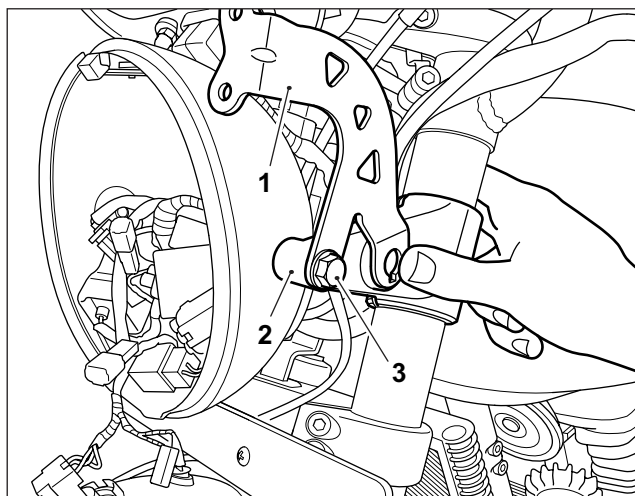

13 Refit the left hand indicator (1), feeding the indicator harness (2) through the mounting bracket (3) and headlight mounting (4), as shown. Refit the original washer and nut to the indicator. Ensure the nut is tightened sufficiently to retain the indicator securely.

Route the indicator harness in to the headlight bowl following the routing noted on removal of the indicator.

WARNING: Ensure the indicator harness is routed correctly in to the headlight bowl. A wiring harness which becomes trapped or pinched during installation may lead to wiring harness damage and electrical malfunctions.

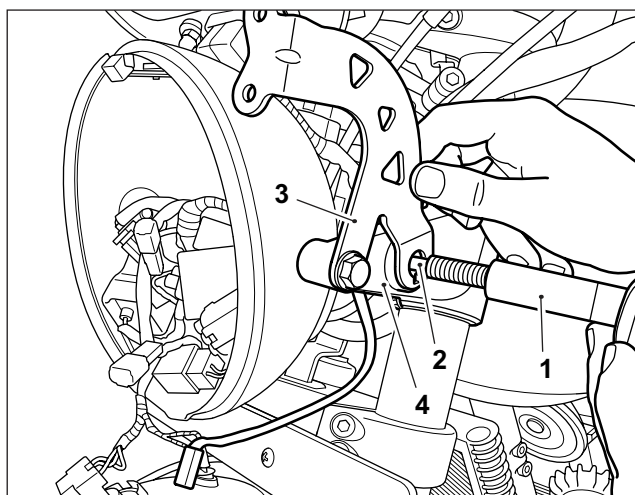

14 Tighten the headlight bowl fixing (1) to **20 Nm**.

15 Repeat steps 9 to 14 for the right hand side of the motorcycle.

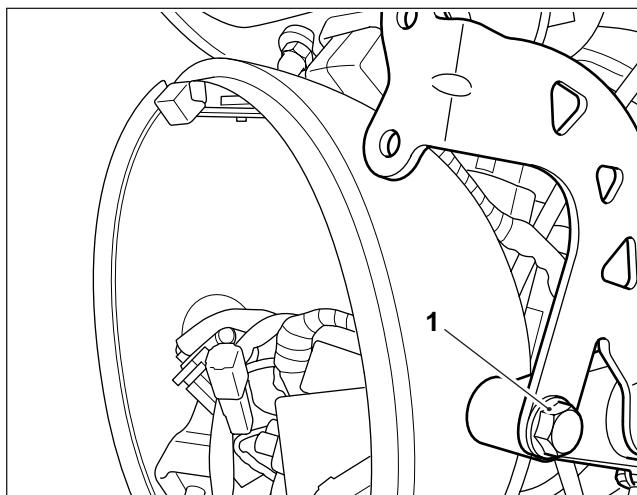

16 Reconnect the left hand (Black) (1) and right hand (White) (2) indicator harness connectors to the main wiring harness.

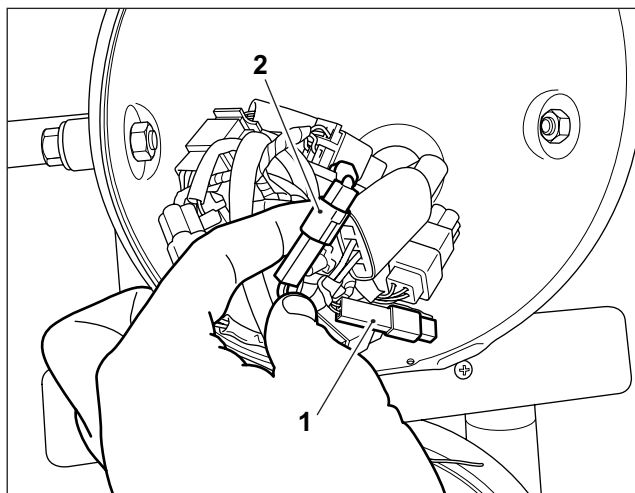

17 Refit the headlight assembly (1) to the headlight bowl (2), ensuring it locates correctly over the retaining clip (3).

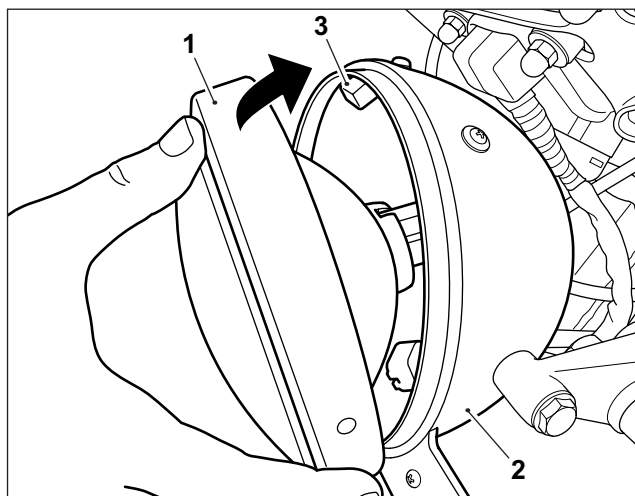

18 Tighten the fixing (1) at the top of the headlight bowl to **5 Nm**.

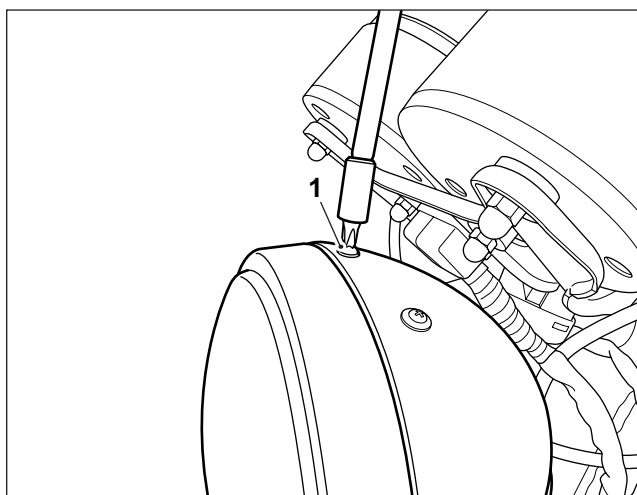

19 Fit the four grommets (1) from the kit into the flyscreen (2).

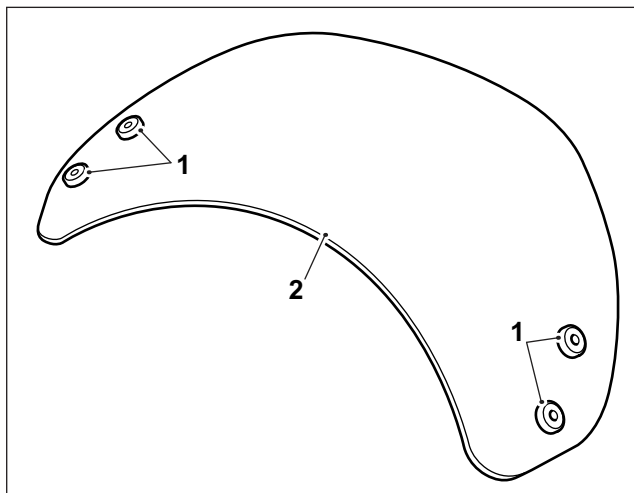

20 Position the embellisher (1) from the kit onto the flyscreen (2), aligning the fixing holes (3) in the embellisher with the grommets in the flyscreen.

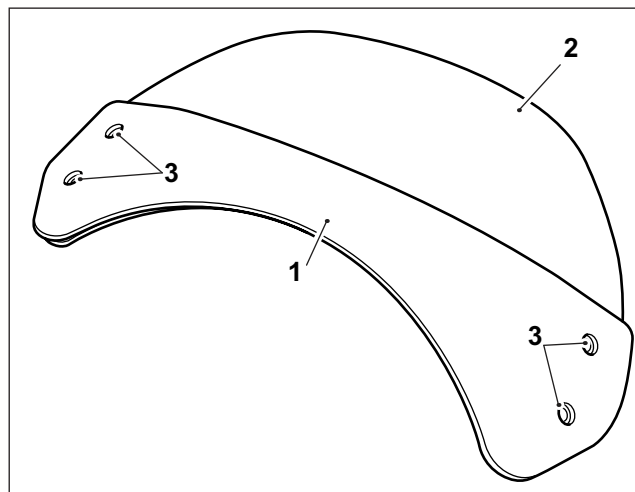

21 Holding the embellisher (1) in position on the flyscreen (2) align the flyscreen fixing positions with the left hand and right hand mounting brackets (3). Fit the M5 x 20mm fixings (4) from the kit. Tighten the fixings to **2Nm**. Left hand side shown.

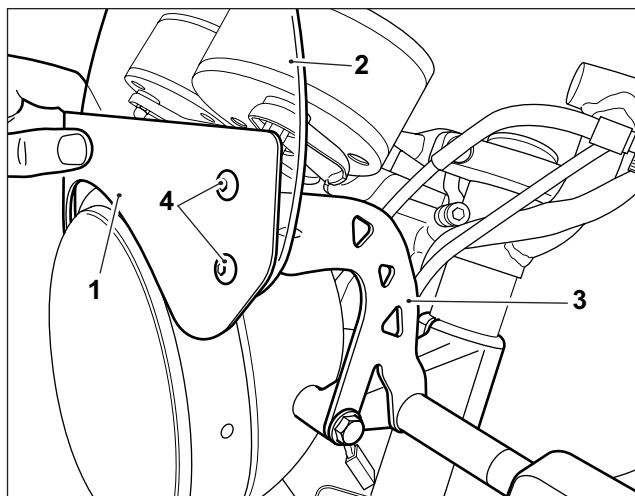

22 Reconnect the battery, positive lead first. Check the headlight and indicators function correctly.

23 Refit the seat to the motorcycle ensuring the front seat retainers (1) locate correctly in the motorcycle frame (2).

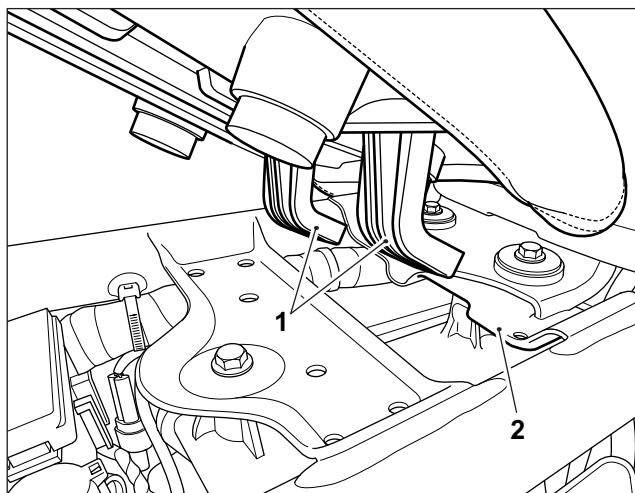

24 Lower the rear of the seat ensuring the seat retaining peg (1) is aligned correctly with the seat latch assembly (2).

Push the rear of the seat down to engage in the seat latch.

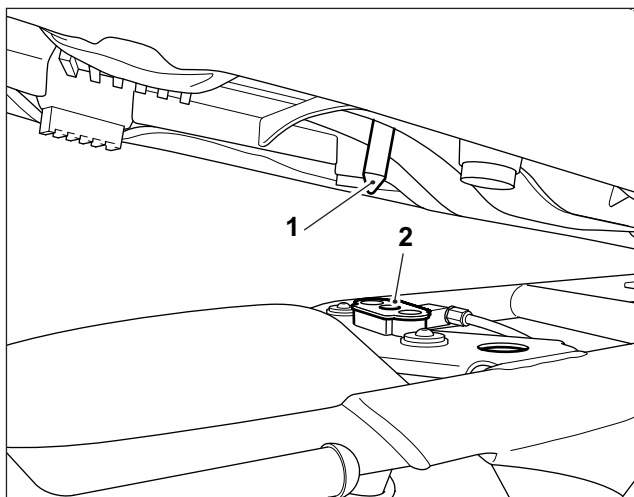

25 Refit the right hand side panel (1) to the retaining pegs (2) on the motorcycle frame. Ensure the grommets (3) remain correctly located in the side panel.

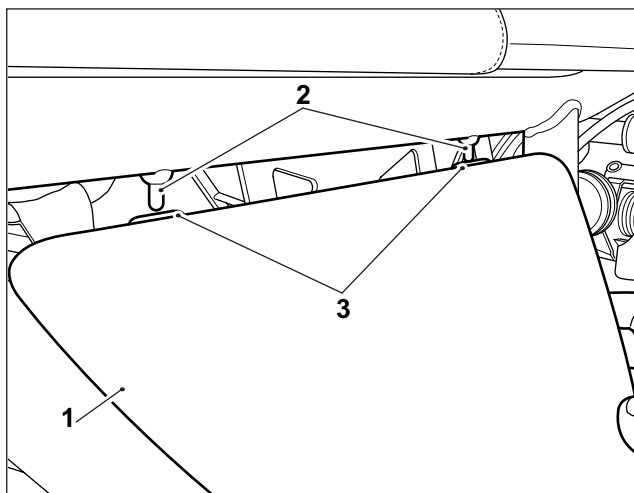

26 Push the bottom of the side panel (1) in towards the motorcycle frame. Turn the ignition key (2) in an anti-clockwise direction to lock the side panel in position.

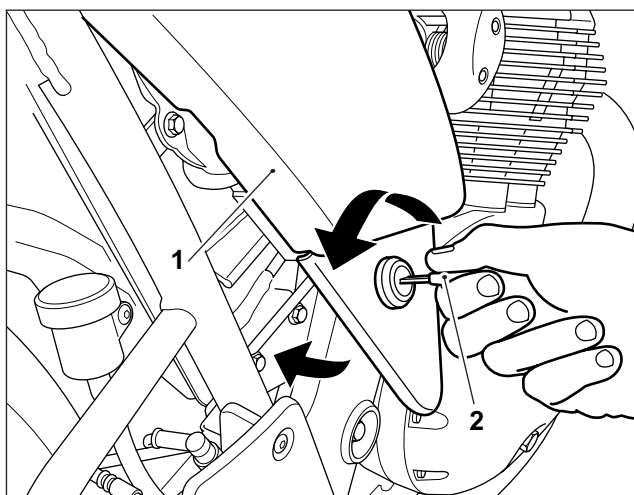

WARNING: Do not attempt to clean the Flyscreen while riding the motorcycle. Any attempt to clean the Flyscreen while riding the motorcycle may cause the motorcycle to become unstable and result in an accident.

WARNING: After fitting any genuine Royal Enfield accessory always ride the motorcycle with caution and allow time to become familiar with any change in the motorcycle handling characteristics. Failure to become familiar with any change in the motorcycle handling characteristics may cause the motorcycle to become unstable and result in an accident.