

Part Number:

1990423

Models :

Continental (2018 onwards)

Interceptor (2018 onwards)

WARNING: Royal Enfield genuine accessories are designed to fit only the specific Royal Enfield motorcycle(s) that are specified above. They should not be fitted to any other type of motorcycle. Pay particular attention to the warnings and cautions contained in this instruction, failure to do so may result in an incorrect installation of the accessory which could result in an unsafe riding condition and possible accident. If in any doubt always seek the help from your authorised Royal Enfield dealer.

WARNING: Before starting any accessory kit installation ensure the motorcycle is supported in a stable condition. Failure to support the motorcycle correctly could lead to motorcycle damage or personal injury.

WARNING: All fixings must be tightened to the torque values specified in this instruction. Failure to tighten fixings to the correct torque could result in an unsafe riding condition and possible accident.

CAUTION: Care should be taken when fitting any accessory kit. Incorrect handling kit components or the use of incorrect tools could lead to component or motorcycle damage.

NOTE: The content of this instruction is subject to change at any time without notice or liability. Royal Enfield reserves the right to revise the information presented at any time.

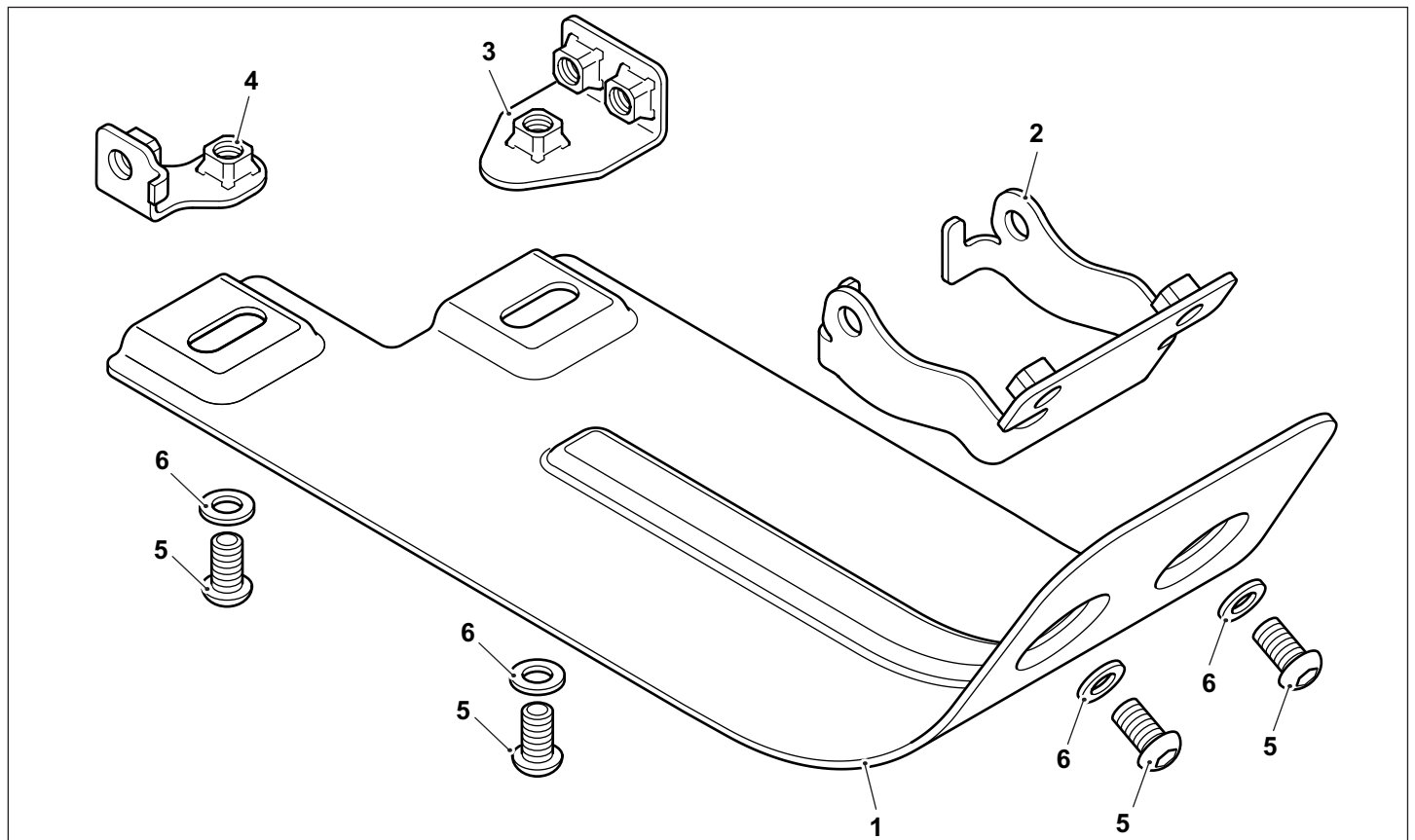

Item	Description	Qty
1	Sump guard	1
2	Front mounting bracket	1
3	Left hand mounting bracket	1
4	Right hand mounting bracket	1
5	Fixing	4
6	Washer	4

⚠ WARNING: If the engine has recently been running the exhaust system will be hot. Before working near to the exhaust system always allow time for the exhaust system to cool. Touching any part of a hot exhaust system will cause burn injuries.

1 Remove the left hand side header pipe retaining nuts (1). Retain the nuts for reuse.
Do not detach the header pipe (2) from the cylinder head at this stage.

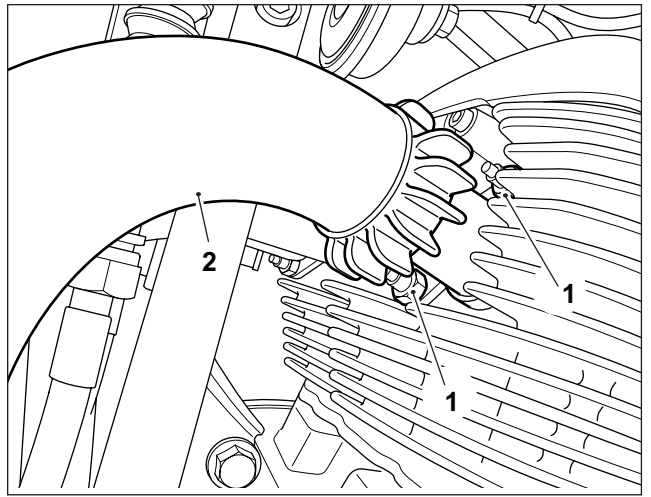

2 Remove the left hand side exhaust centre fixing (1). Retain the fixing for reuse.

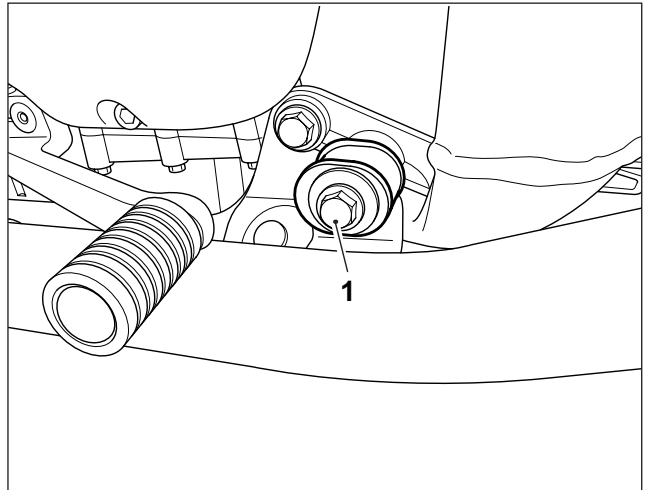

3 While supporting the exhaust system, remove the left hand side silencer mounting bracket fixing (1). Retain the fixing, washers (2), rubber bushes (3) and nut (4) for reuse.

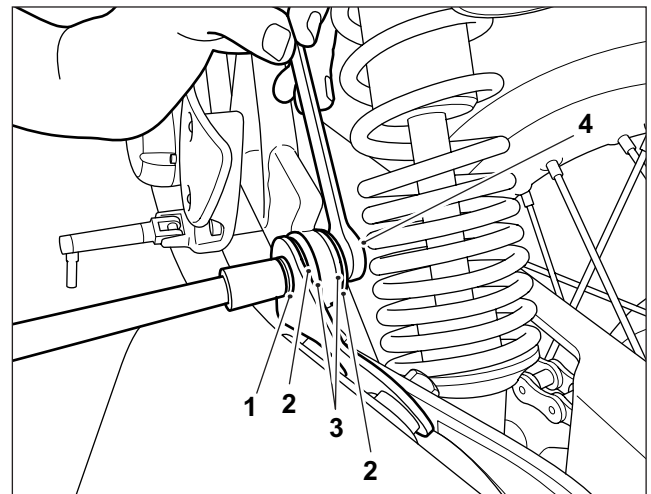

4 Carefully disengage the left hand side exhaust system header pipe (1) from the cylinder head and ensure the exhaust system is fully supported and not allowed to hang from the oxygen sensor harness (2).

5 Repeat steps 1 to 4 for the right hand side exhaust system.

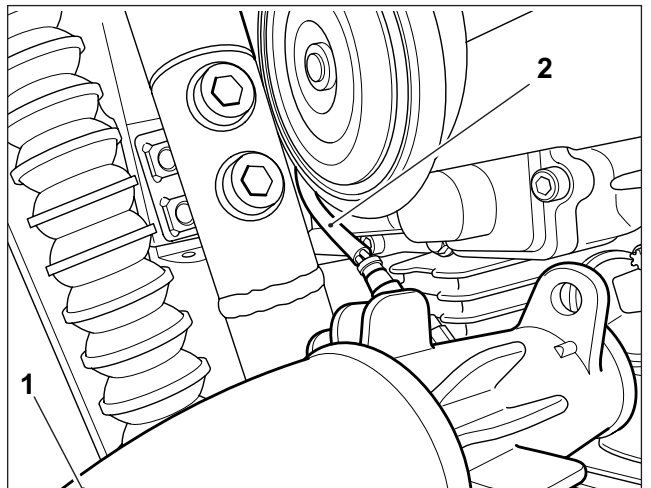

6 Remove the two cradle fixings (1) on the left hand side of the motorcycle. Retain the fixings for reuse. Retain the weld nut plate (2) for reuse if the accessory sump guard is removed.

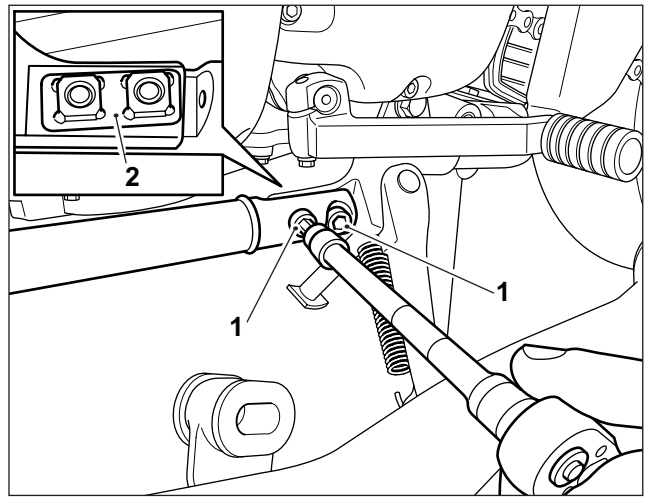

7 Position the left hand rear mounting bracket (1) from the kit on to the cradle (2) in the orientation shown. Fit the original fixings (3). Tighten the fixings to **45 Nm**.

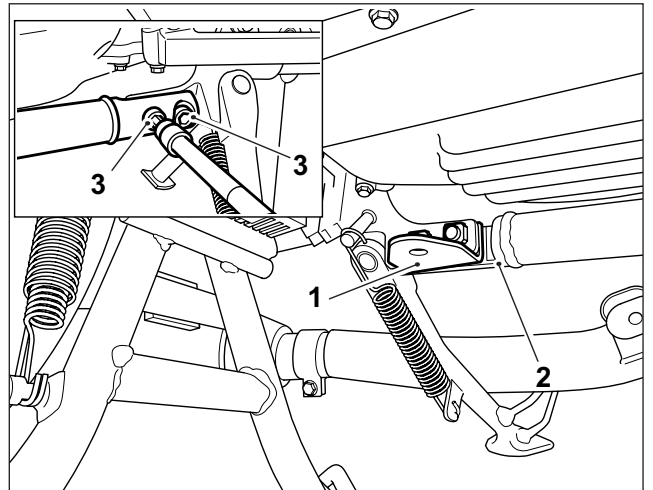

8 Remove the single cradle fixing (1) on the right hand side of the motorcycle. Retain the fixing for reuse, retain the nut (2) for reuse if the accessory sump guard is removed.

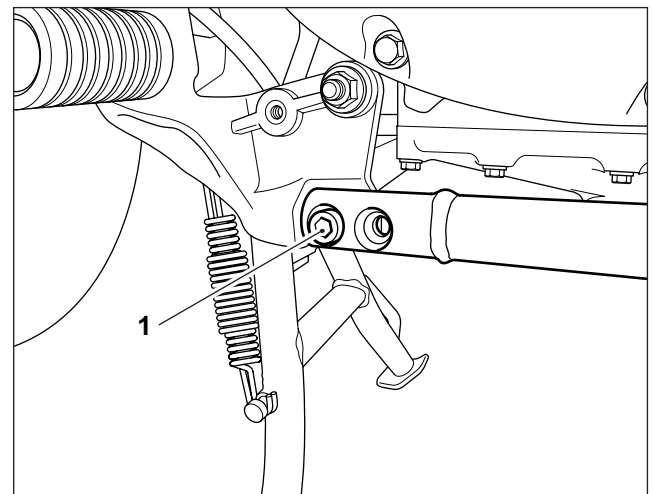

9 Position the right hand rear mounting bracket (1) from the kit on to the cradle (2) in the orientation shown. Fit the original fixing (3). Do not fully tighten the fixing at this stage.

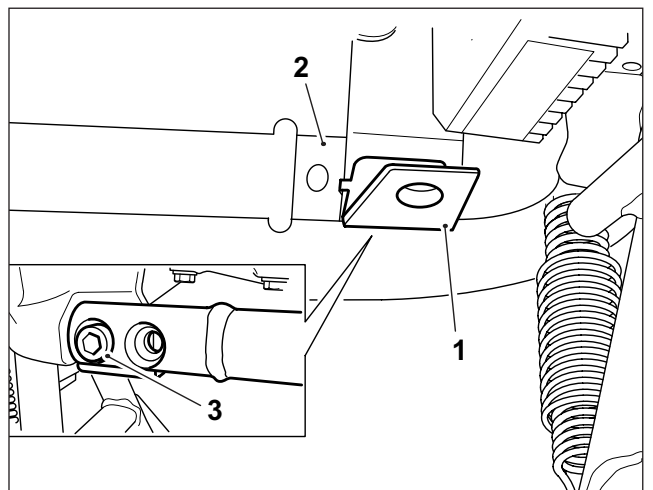

10 Remove the front lower engine mounting fixings (1) washers (2), nuts (3) and washers (4) from the left hand and right hand side of the motorcycle. Retain the fixings (1), washers (2) and nuts (3) and for reuse. Retain the washers (4) for reuse if the accessory sump guard is removed.

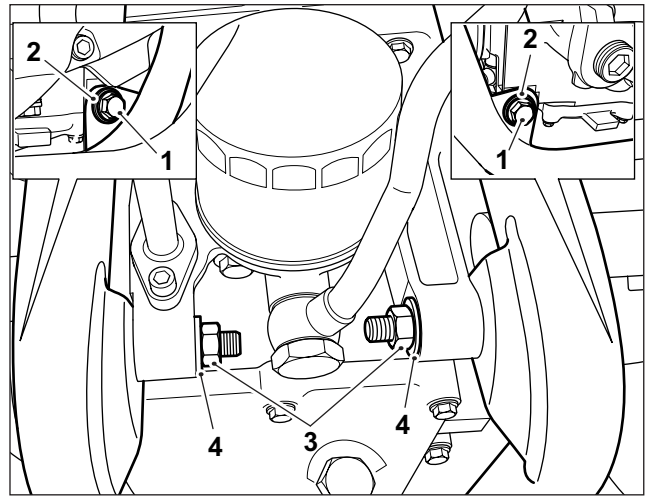

11 Position the sump guard front mounting bracket (1) from the kit into the motorcycle frame in the orientation shown. Align the mounting bracket (1) with the lower engine mountings and refit the original fixings (2), washers (3) and nuts (4). Do not fully tighten the fixings at this stage.

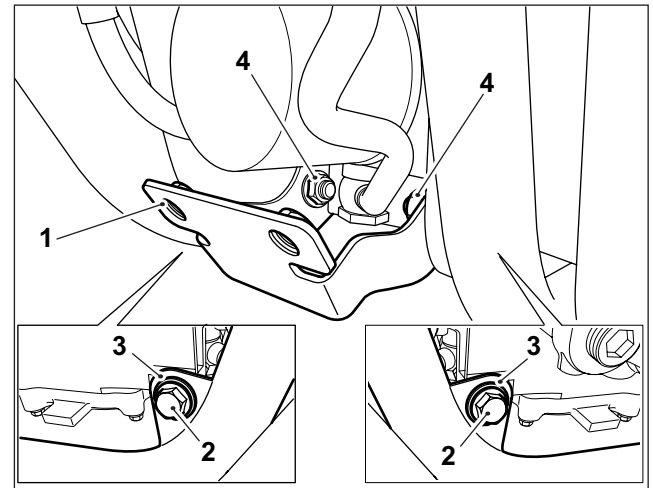

12 Position the accessory sump guard (1) from the kit on to the front mounting bracket (2) aligning the sump guard with the mounting bracket weld nuts (3). Loosely fit two of the fixings (4) and washers (5) from the kit.

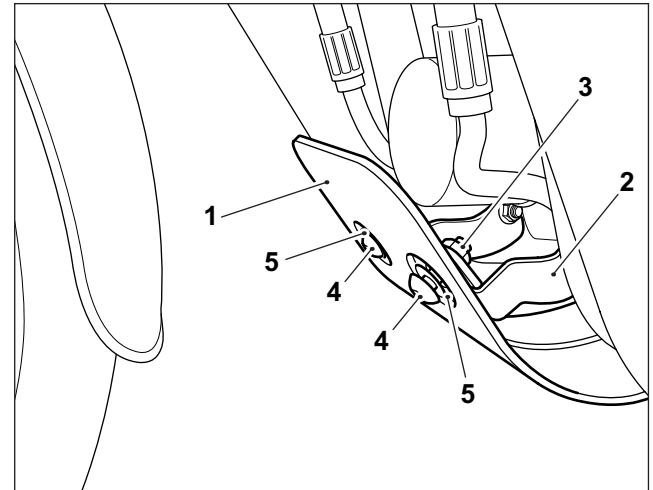

13 Align the rear fixing positions of the sump guard (1) with the left hand (2) and right hand (3) mounting brackets and loosely fit the fixings (4) and washers (5) from the kit.

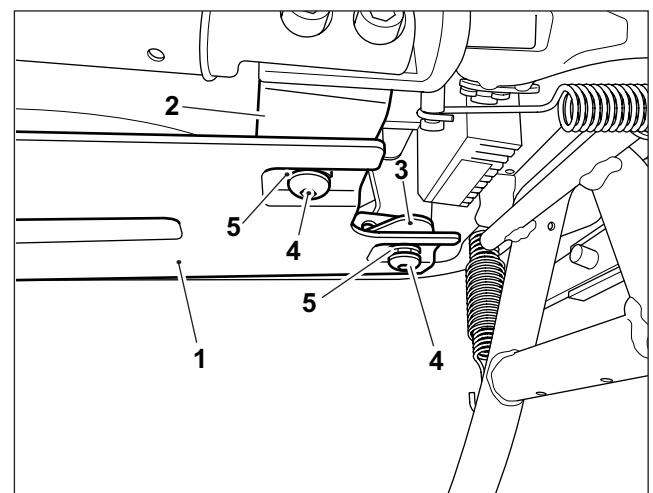

14 Tighten the lower engine mounting fixings (1) to **45 Nm**, left hand side shown.

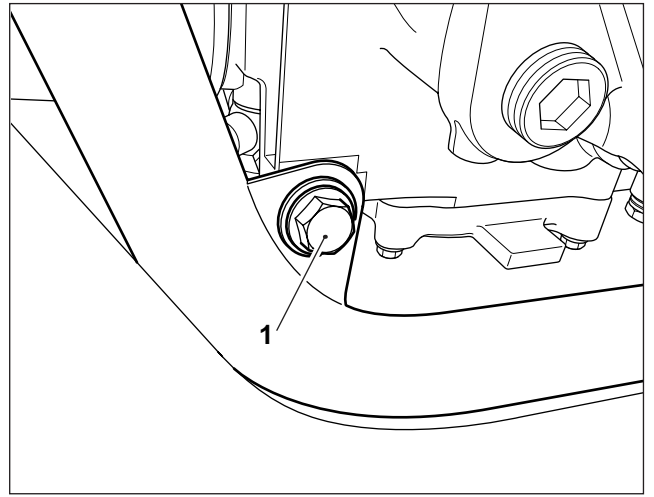

15 Tighten the right hand side cradle fixing (1) to **45 Nm**.

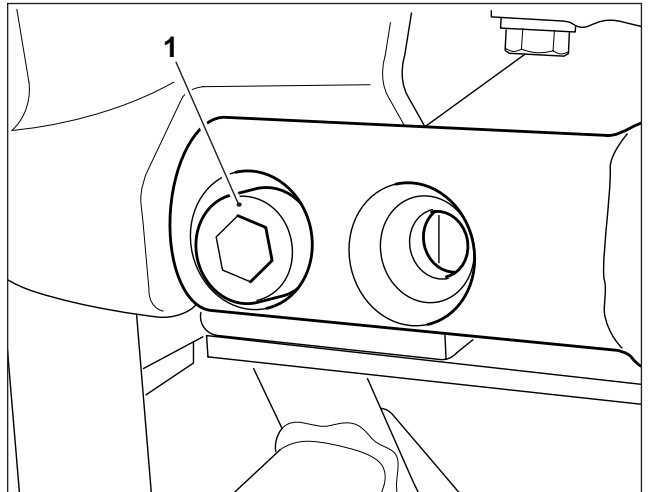

16 Tighten the accessory sump guard fixings (1) to **20 Nm**.

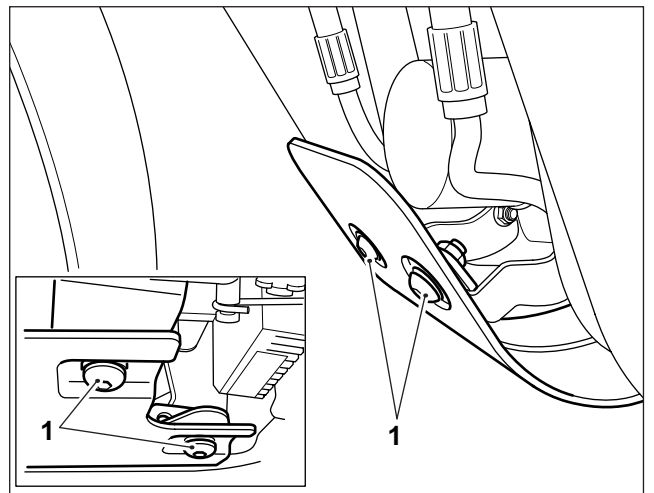

17 Ensuring the exhaust system remains supported refit the left hand side header pipe (1) to the cylinder head. Do not fully tighten the retaining nuts (2) at this stage.

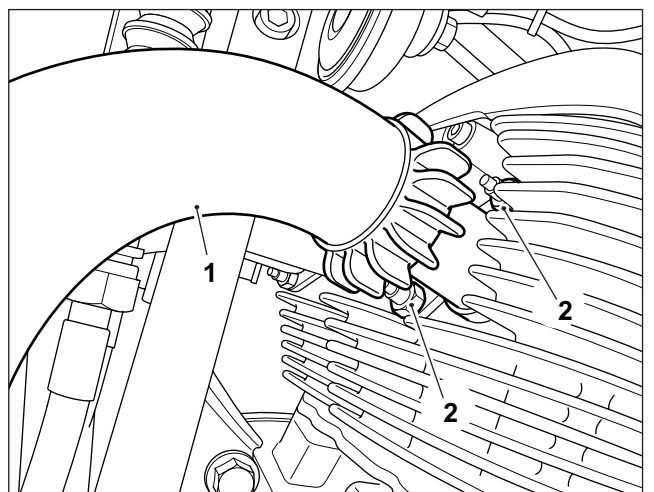

18 Refit the left hand side exhaust system centre fixing (1) ensuring the flanged sleeve (2) is positioned correctly, as shown. Do not fully tighten the fixing at this stage.

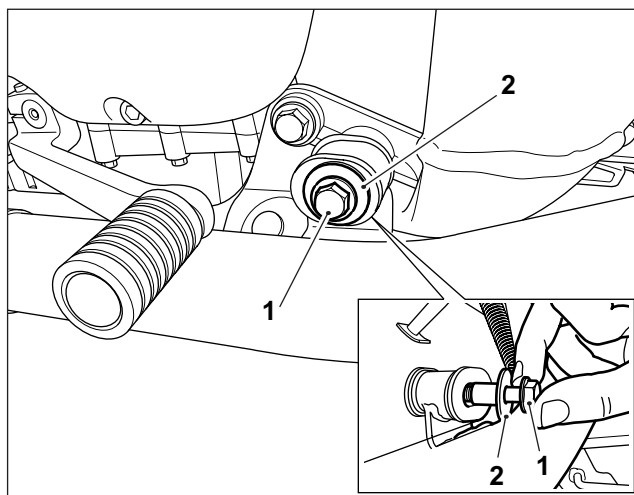

19 Refit the left hand side silencer mounting bracket fixing (1) and nut (2) ensuring the rubber bushes (3) and washers (4) are positioned as shown. Do not fully tighten the fixing at this stage.

20 Tighten the exhaust header pipe fixings to **15 Nm**.
Tighten the exhaust centre fixing to **22 Nm**.
Tighten the silencer mounting bracket fixing to **22 Nm**.

21 Repeat steps 17 to 20 for the right hand side exhaust system.

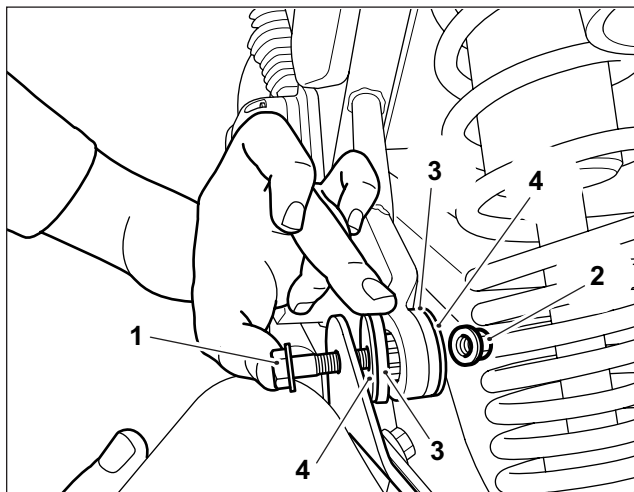

WARNING: After fitting any genuine Royal Enfield accessory always ride the motorcycle with caution and allow time to become familiar with any change in the motorcycle handling characteristics. Failure to become familiar with any change in the motorcycle handling characteristics may cause the motorcycle to become unstable and result in an accident.