

Part Number:

1990441

1990457

Models :

Continental (2018 onwards)

Interceptor (2018 onwards)

WARNING: Royal Enfield genuine accessories are designed to fit only the specific Royal Enfield motorcycle(s) that are specified above. They should not be fitted to any other type of motorcycle. Pay particular attention to the warnings and cautions contained in this instruction, failure to do so may result in an incorrect installation of the accessory which could result in an unsafe riding condition and possible accident. If in any doubt always seek the help from your authorised Royal Enfield dealer.

WARNING: Before starting any accessory kit installation ensure the motorcycle is supported in a stable condition. Failure to support the motorcycle correctly could lead to motorcycle damage or personal injury.

WARNING: All fixings must be tightened to the torque values specified in this instruction. Failure to tighten fixings to the correct torque could result in an unsafe riding condition and possible accident.

NOTE: The content of this instruction is subject to change at any time without notice or liability. Royal Enfield reserves the right to revise the information presented at any time.

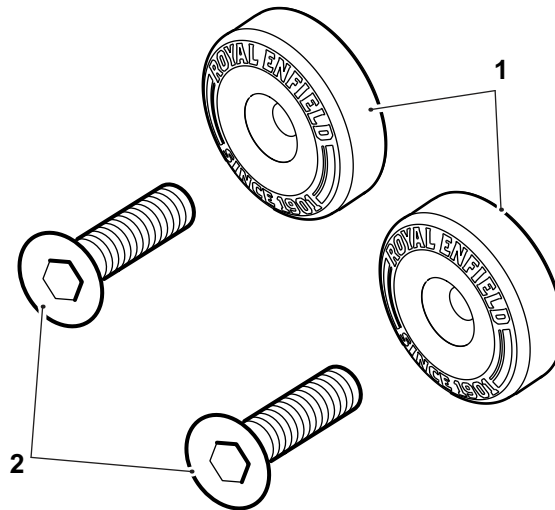

Item	Description	Qty
1	Bar end weight	2
2	Fixing, M6 x 20mm	2

NOTE: The accessory bar end weights can be fitted to motorcycles with standard mirrors, or accessory bar end mirrors fitted. The fitting procedure is the same regardless of the type of mirrors fitted to the motorcycle.

1 Remove the original bar end weight fixing (1) and bar end weight (2) from the left hand side of the handlebars. Hold bar end weight when unscrewing fixing. Retain the bar end weight and fixing for reuse if the accessory bar end weight is removed.

2 Fit an accessory bar end weight (1) from the kit on to the left hand side of the handlebars ensuring the bar end weight orientation is aligned correctly with the anti-rotation feature (2) in the end of the handlebar as shown. Fit a fixing (3) from the kit and tighten the fixing to **10Nm**.

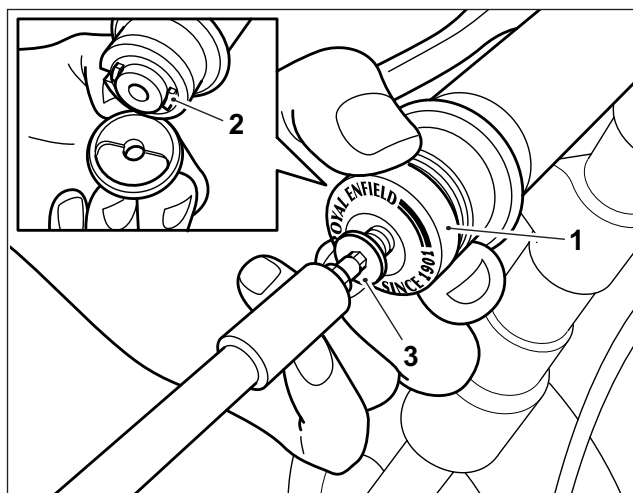
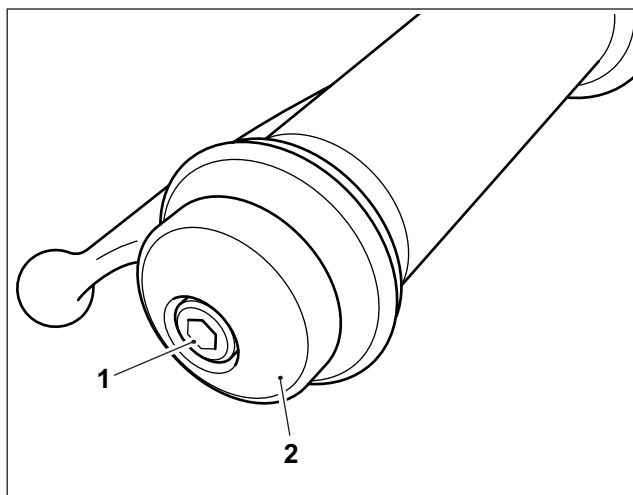

Repeat steps 1 and 2 for the right hand side of the motorcycle.

WARNING: Ensure that the operation of the twist grip (1) is smooth, without tightness and will return to the throttle closed position when released. A tight or sticking twist grip can lead to loss of motorcycle control and an accident.

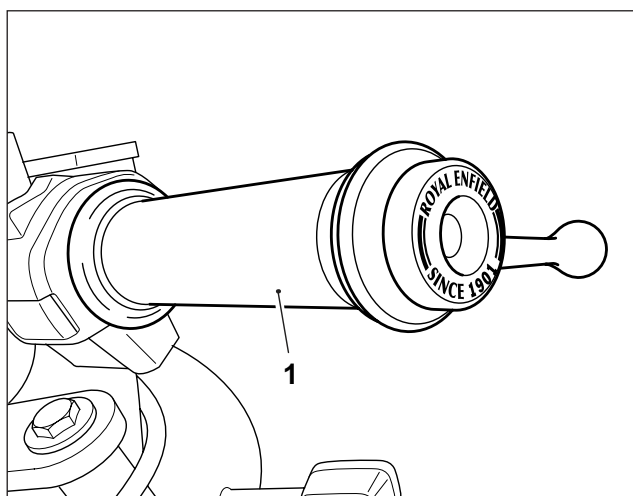

WARNING: After fitting any genuine Royal Enfield accessory always ride the motorcycle with caution and allow time to become familiar with any change in the motorcycle handling characteristics. Failure to become familiar with any change in the motorcycle handling characteristics may cause the motorcycle to become unstable and result in an accident.