

**Part Number:**

1990603 (Black)  
1990604 (Stainless Steel)

**Models:**

Classic 350cc, Classic 500cc,  
Bullet 350cc, Bullet 500cc,  
Electra 350cc

**WARNING:** Royal Enfield genuine accessories are designed to fit only the specific Royal Enfield motorcycle(s) that are specified above. They should not be fitted to any other type of motorcycle. Pay particular attention to the warnings and cautions contained in this instruction, failure to do so may result in an incorrect installation of the accessory which could result in an unsafe riding condition and possible accident. If in any doubt always seek the help from your authorised Royal Enfield dealer.

**WARNING:** Before starting any accessory kit installation ensure the motorcycle is supported in a stable condition. Failure to support the motorcycle correctly could lead to motorcycle damage or personal injury.

**WARNING:** All fixings must be tightened to the torque values specified in this instruction. Failure to tighten fixings to the correct torque could result in an unsafe riding condition and possible accident.

**CAUTION:** Care should be taken when fitting any accessory kit. Incorrect handling kit components or the use of incorrect tools could lead to component or motorcycle damage.

**NOTE:** The content of this instruction is subject to change at any time without notice or liability. Royal Enfield reserves the right to revise the information presented at any time.

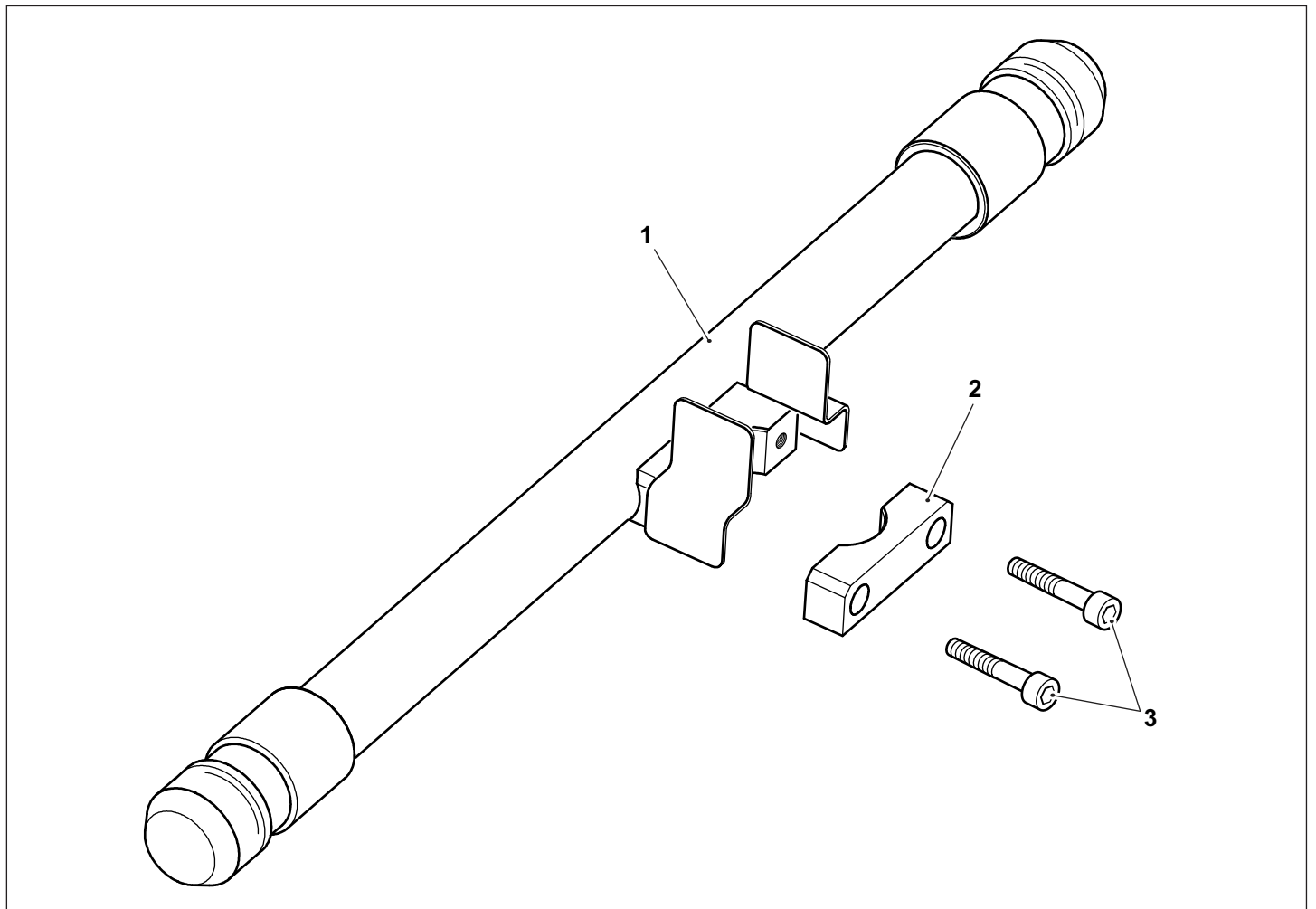

Item	Description	Qty
1	Engine guard	1
2	Rear clamp	1
3	Fixing, M8 x 45mm	2

**⚠ WARNING:** If the engine has recently been running the exhaust system will be hot. Before working near to the exhaust system always allow time for the exhaust system to cool. Touching any part of a hot exhaust system will cause burn injuries.

**1** Remove the top rubber strap (1) securing the wiring harnesses to the motorcycle frame, as shown. Retain the strap for reuse.

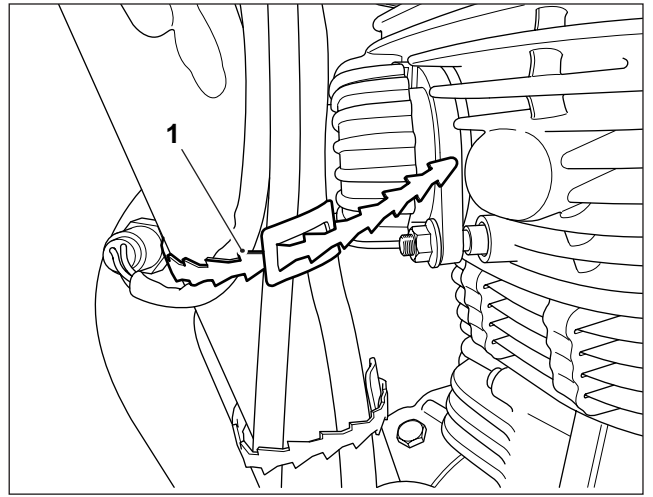

**2** Position the engine bar (1) on the front of the frame down tube (2) just below the frame plates (3), as shown. Ensure no wiring harnesses become trapped between the engine bar and motorcycle frame. If an oxygen sensor is fitted to the motorcycle ensure the oxygen sensor harness (4) is routed under the engine bar mounting clamp section (5), as shown.

**⚠ WARNING:** A wiring harness which becomes trapped or pinched during installation of the engine bar may lead to wiring harness damage and electrical malfunctions.

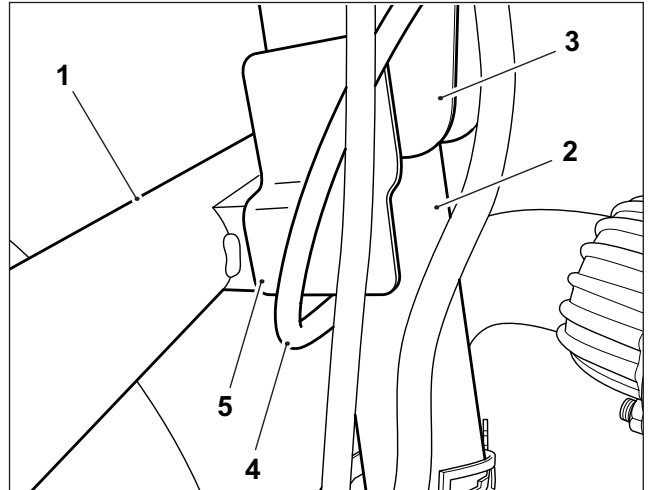

**3** Ensure the mounting clamp section (1) of the engine bar (2) is located against the frame plates (3), as shown.

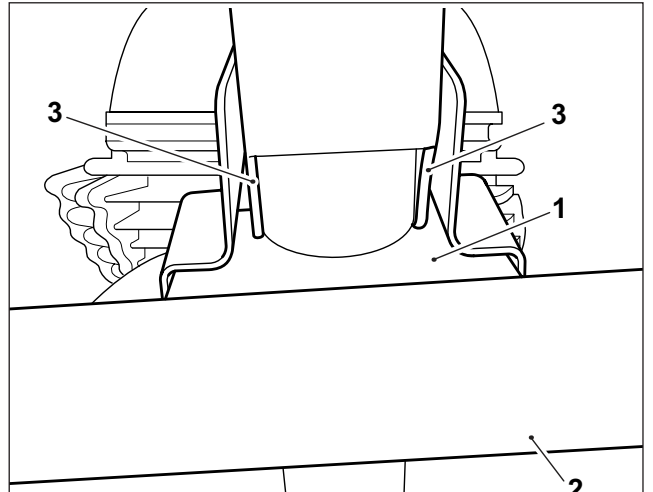

**4** Fit the rear clamp (1) provided and secure with the M8 x 45 mm fixings (2). Ensure no wiring harnesses become trapped between the rear clamp (1) and motorcycle frame downtube (3), or frame plates (4).

Tighten the fixings (2) evenly to maintain an equal gap between the engine bar (5) and rear clamp (1) on both sides of the motorcycle.

Apply a final torque to both fixings of **22Nm**.

**⚠ WARNING:** A wiring harness which becomes trapped or pinched during installation of the engine bar may lead to wiring harness damage and electrical malfunctions.

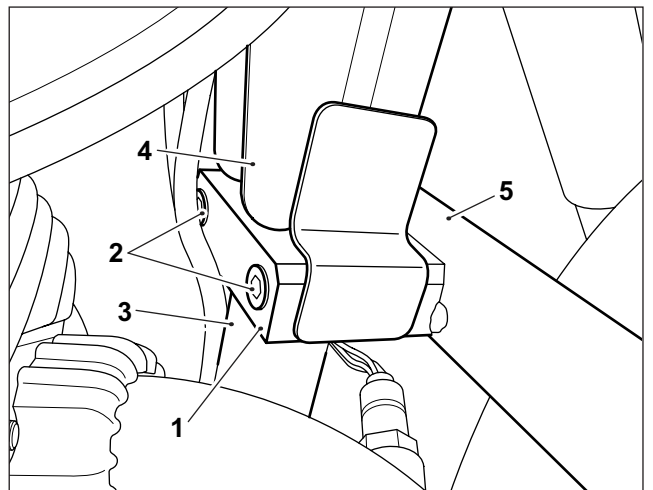

**5** Refit the rubber strap (1) to retain the wiring harnesses to the motorcycle frame, as shown.

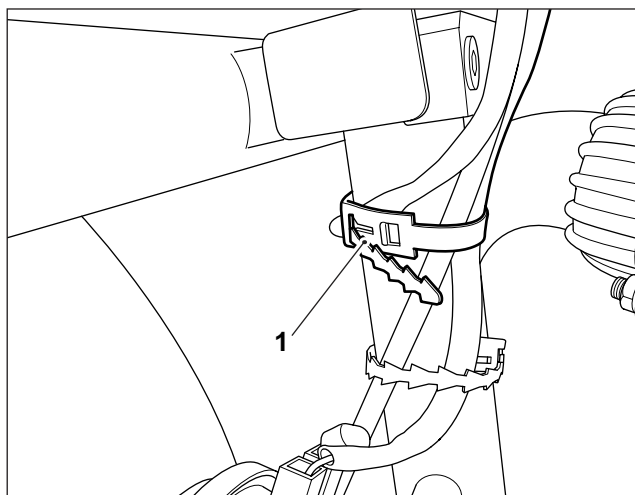

**⚠ WARNING:** After fitting any genuine Royal Enfield accessory always ride the motorcycle with caution and allow time to become familiar with any change in the motorcycle handling characteristics. Failure to become familiar with any change in the motorcycle handling characteristics may cause the motorcycle to become unstable and result in an accident.