

**Part Number:**

1990605

**Models:**

Classic 350cc, Classic 500cc

**WARNING:** Royal Enfield genuine accessories are designed to fit only the specific Royal Enfield motorcycle(s) that are specified above. They should not be fitted to any other type of motorcycle. Pay particular attention to the warnings and cautions contained in this instruction, failure to do so may result in an incorrect installation of the accessory which could result in an unsafe riding condition and possible accident. If in any doubt always seek the help from your authorised Royal Enfield dealer.

**WARNING:** Before starting any accessory kit installation ensure the motorcycle is supported in a stable condition. Failure to support the motorcycle correctly could lead to motorcycle damage or personal injury.

**WARNING:** All fixings must be tightened to the torque values specified in this instruction. Failure to tighten fixings to the correct torque could result in an unsafe riding condition and possible accident.

**CAUTION:** Care should be taken when fitting any accessory kit. Incorrect handling kit components or the use of incorrect tools could lead to component or motorcycle damage.

**NOTE:** The content of this instruction is subject to change at any time without notice or liability. Royal Enfield reserves the right to revise the information presented at any time.

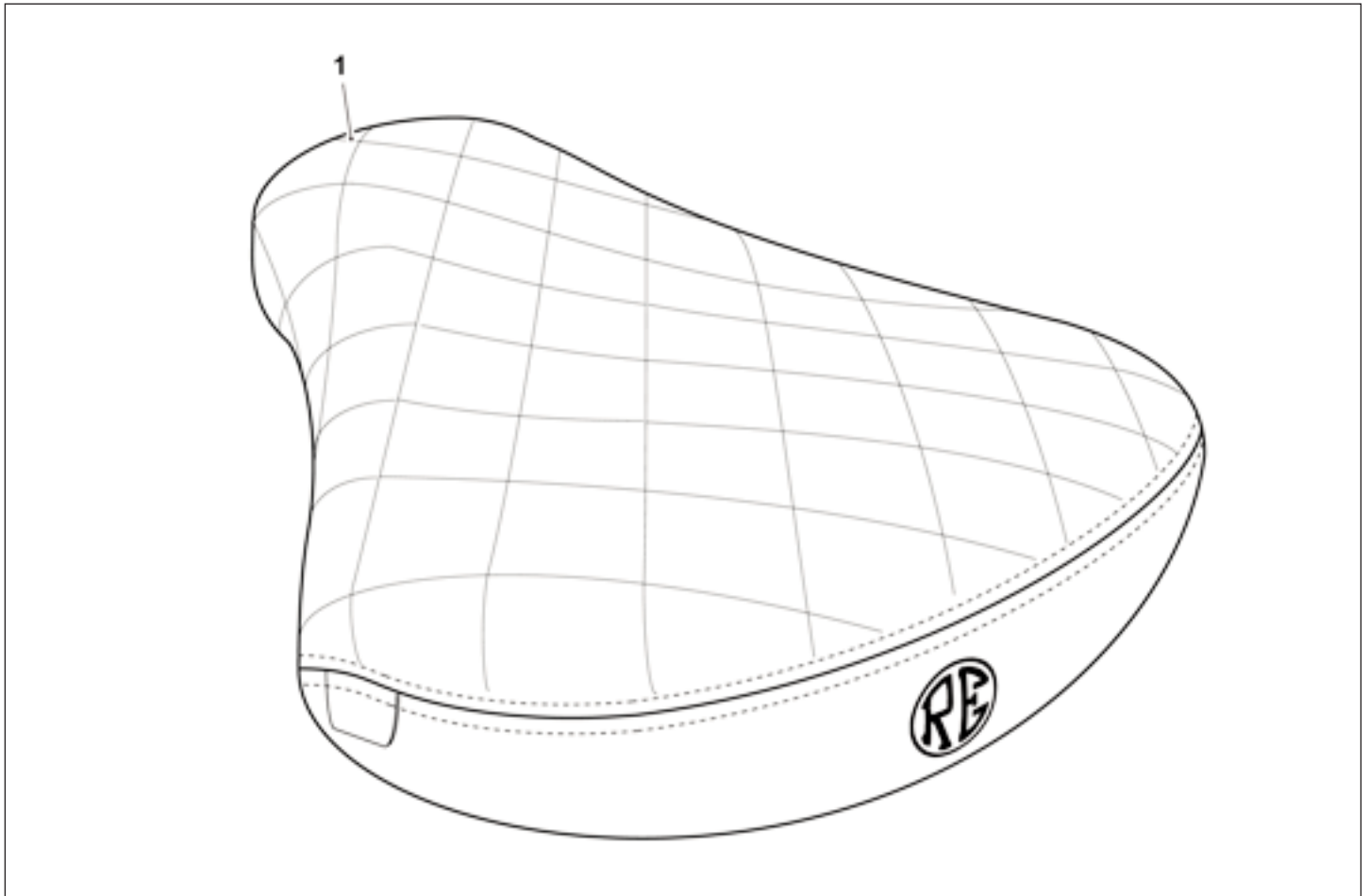

Item	Description	Qty
1	Rider seat	1

**1** Remove the seat rear fixings (1), nuts (2) and spring collars (3) from the left hand side of the motorcycle. Retain the fixings (1), nuts (2) and spring collars (3) for reuse.

Repeat for the right hand side of the seat.

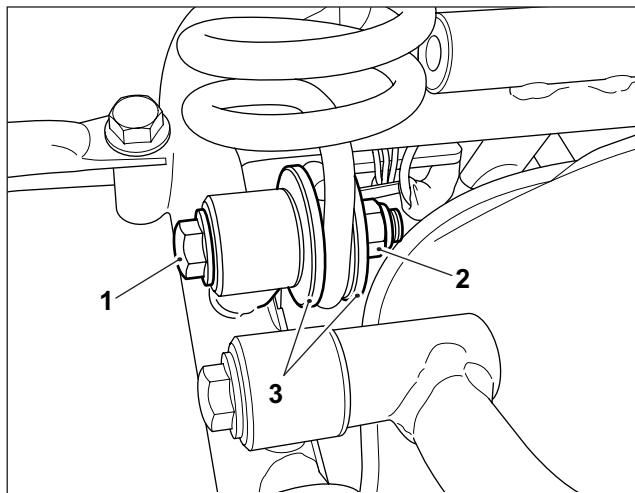

**2** Remove the front seat fixing (1) from the right hand side of the motorcycle. Remove the seat.

**NOTE:** California models only.

For models carrying emission vent pipes, the pipework must be re-routed under the frame rails.

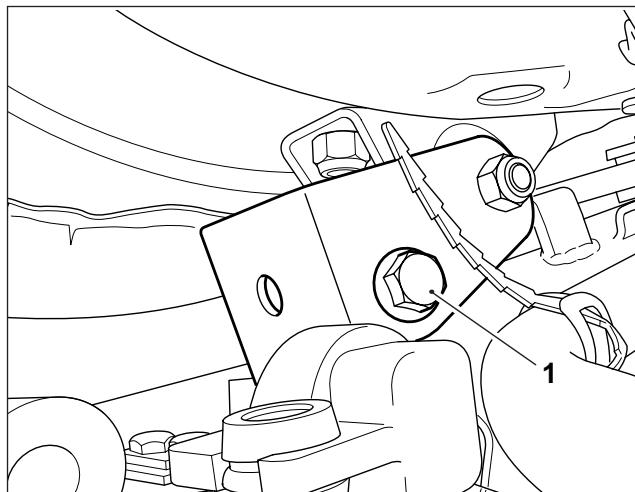

**3** Place the seat, cushion side down, on a clean flat work surface. Remove one of the lock nuts (1) from the front mounting bracket retaining pin (2), as shown. Retain the lock nut (1) for reuse.

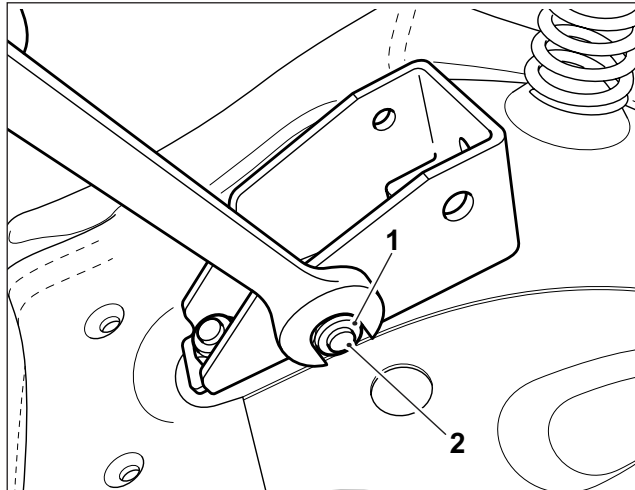

**NOTE:** Before removing the front mounting bracket (1) note its position relative to the seat mounting (2) to help reassembly.

**4** Remove the front mounting bracket retaining pin (3), as shown and remove the front mounting bracket (1) from the front seat mounting (2). Retain the front mounting bracket (1) and retaining pin (3) for reuse.

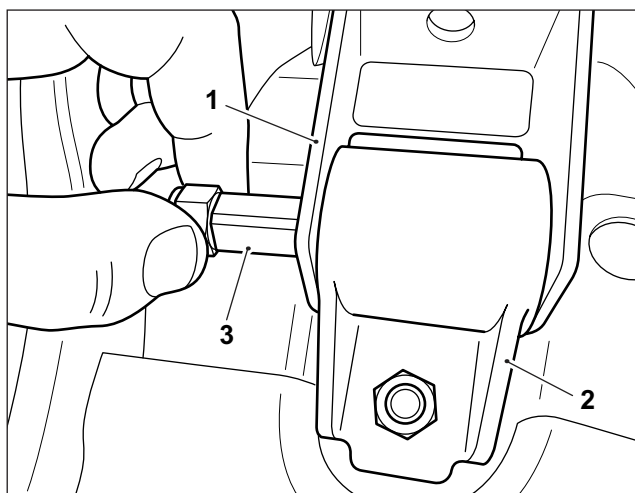

**NOTE:** Before removing the front seat mounting (3) note its orientation on the seat base to help reassembly.

**5** Remove the lock nuts (1) and washers (2) securing the front seat mounting (3) to the seat base. Retain the lock nuts, washers and front seat mounting for reuse.

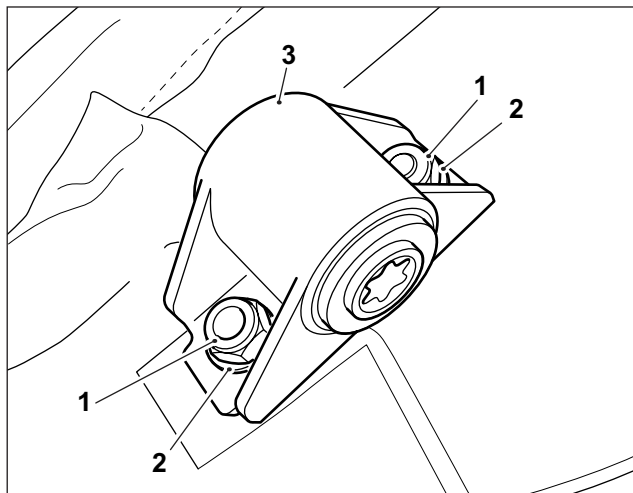

**6** Remove the nuts (1) and washers (2) retaining the springs (3) to the seat base and remove the springs, left hand side shown. Retain the springs, nuts and washers for reuse. Retain the original seat for reuse if the accessory seat is removed.

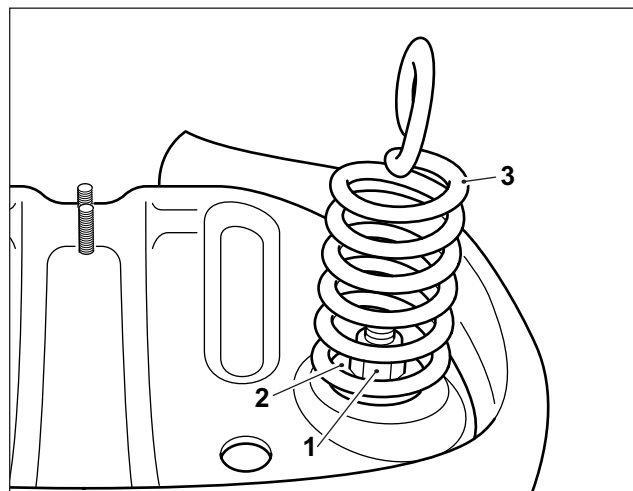

**7** Place the accessory seat from the kit, cushion side down, on a clean flat surface. Fit the original springs (1) onto the seat base and secure with the original nuts (2) and washers (3). Ensure the springs are in the orientation shown and the spring mountings (4) are parallel to the centre of the seat.

Tighten the nuts (2) to **25 Nm**.

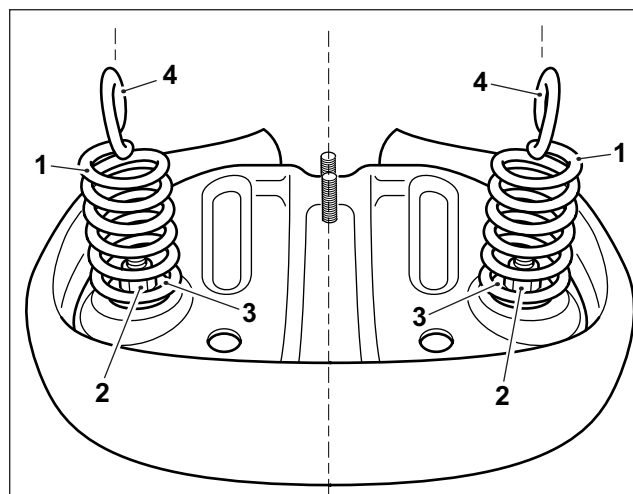

**8** Fit the original front seat mounting (1) on to the mounting studs (2) in the seat base in the correct orientation, as noted on removal. Fit original washers (3) and lock nuts (4). Tighten the lock nuts to **25 Nm**.

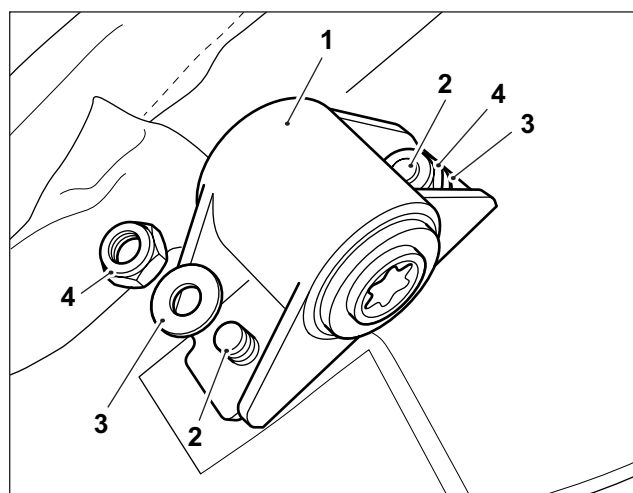

**9** Refit the original front seat mounting bracket (1) on to the front seat mounting (2) in the position noted at removal and refit the front mounting bracket retaining pin (3) as shown. Refit the original lock nut (4) to the retaining pin and tighten the lock nut to **25 Nm**.

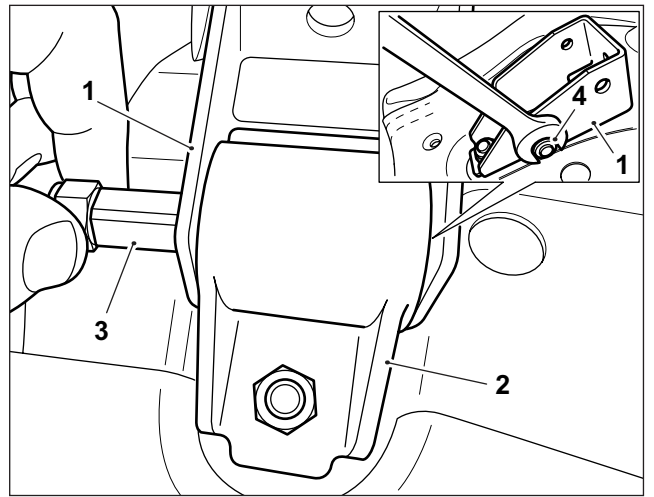

**10** Fit the accessory seat on to the motorcycle aligning the seat front mounting bracket (1) with the mounting (2) on the motorcycle frame.

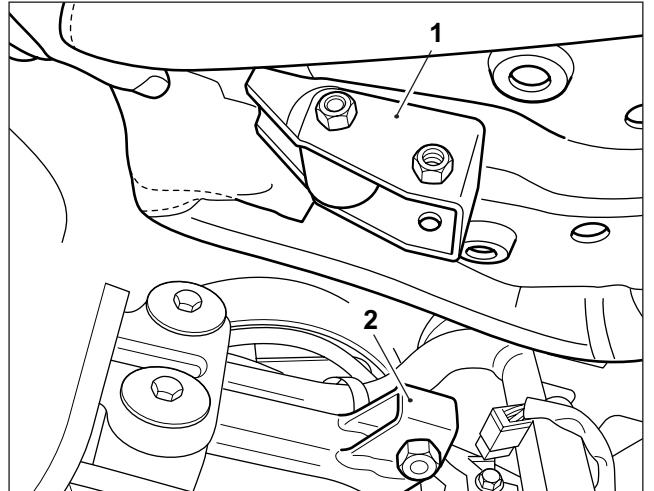

**11** Fit the original seat front fixing (1) from the right hand side of the motorcycle, as shown. Do not fully tighten the fixing at this stage.

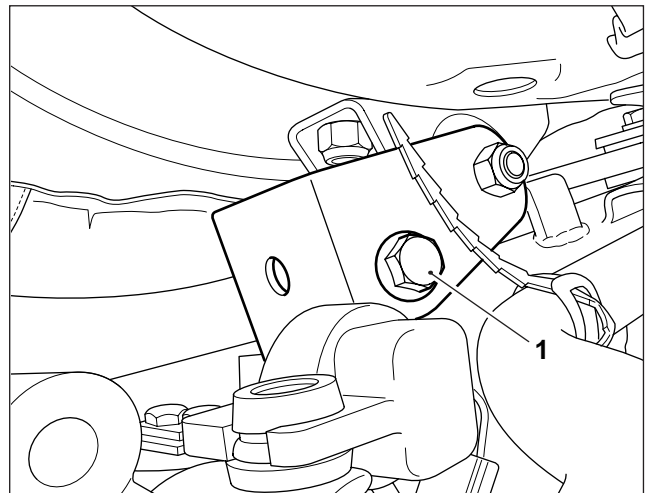

**12** Align the left hand seat seat spring mounting (1) with the original seat mounting point (2) on the motorcycle frame. Loosely fit one of the original fixings (3), the collars (4) and nut (5) ensuring the collars (4) locate correctly in the spring mounting (1), as shown.

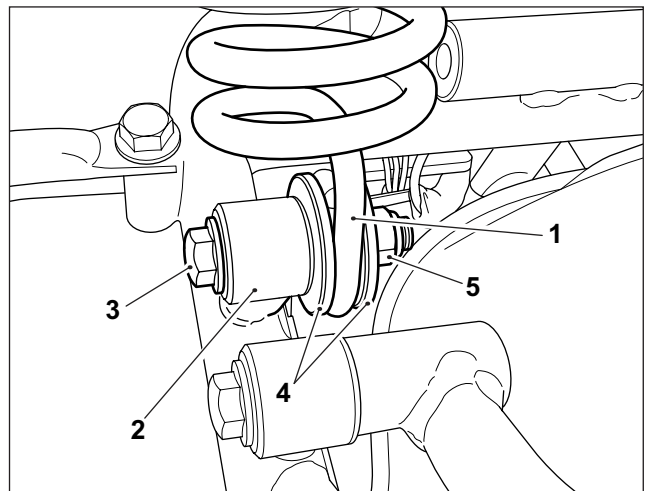

Repeat for the right hand side of the seat.

Tighten spring fixings (3) to **25 Nm**

**13** Tighten the front seat mounting fixing (1) to **25 Nm**.

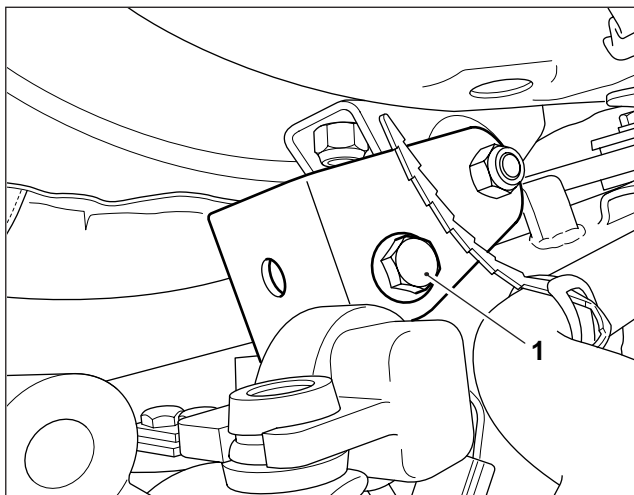

**WARNING:** Check the new seat is securely attached to the motorcycle. If the seat is not correctly secured to the motorcycle it may allow movement or possible detachment of the seat while riding. A loose or detached seat may cause the motorcycle to become unstable and result in an accident.

**WARNING:** After fitting any genuine Royal Enfield accessory always ride the motorcycle with caution and allow time to become familiar with any change in the motorcycle handling characteristics. Failure to become familiar with any change in the motorcycle handling characteristics may cause the motorcycle to become unstable and result in an accident.