

Part Number:

1990620 Pannier Mounts, Pair, Fabricated, Black (Drum Brake)
1990638 Pannier Mount, RH, Fabricated, Black (Drum Brake)
1990670 Pannier Mounts, Pair, Fabricated, Black (Disc Brake)
1990671 Pannier Mount, RH, Fabricated, Black (Disc Brake)
1990618 Pannier Kit, Pair, Wax Canvas Olive Green
1990619 Pannier Kit, Pair, Wax Canvas Black
1990646 Pannier Kit, Pair, Wax Canvas Sand (Pegasus Edition)
1990654 Pannier Kit, Single, Wax Canvas Olive Green
1990655 Pannier Kit, Single, Wax Canvas Black

Models :

Classic 350cc, Classic 500cc

 **WARNING:** Royal Enfield genuine accessories are designed to fit only the specific Royal Enfield motorcycle(s) that are specified above. They should not be fitted to any other type of motorcycle. Pay particular attention to the warnings and cautions contained in this instruction, failure to do so may result in an incorrect installation of the accessory which could result in an unsafe riding condition and possible accident. If in any doubt always seek the help from your authorised Royal Enfield dealer.

 **WARNING:** Before starting any accessory kit installation ensure the motorcycle is supported in a stable condition. Failure to support the motorcycle correctly could lead to motorcycle damage or personal injury.

 **WARNING:** All fixings must be tightened to the torque values specified in this instruction. Failure to tighten fixings to the correct torque could result in an unsafe riding condition and possible accident.

 **CAUTION:** Care should be taken when fitting any accessory kit. Incorrect handling kit components or the use of incorrect tools could lead to component or motorcycle damage.

NOTE: The content of this instruction is subject to change at any time without notice or liability. Royal Enfield reserves the right to revise the information presented at any time.

1990620, 1990670 Pannier Mount Kit - Pair

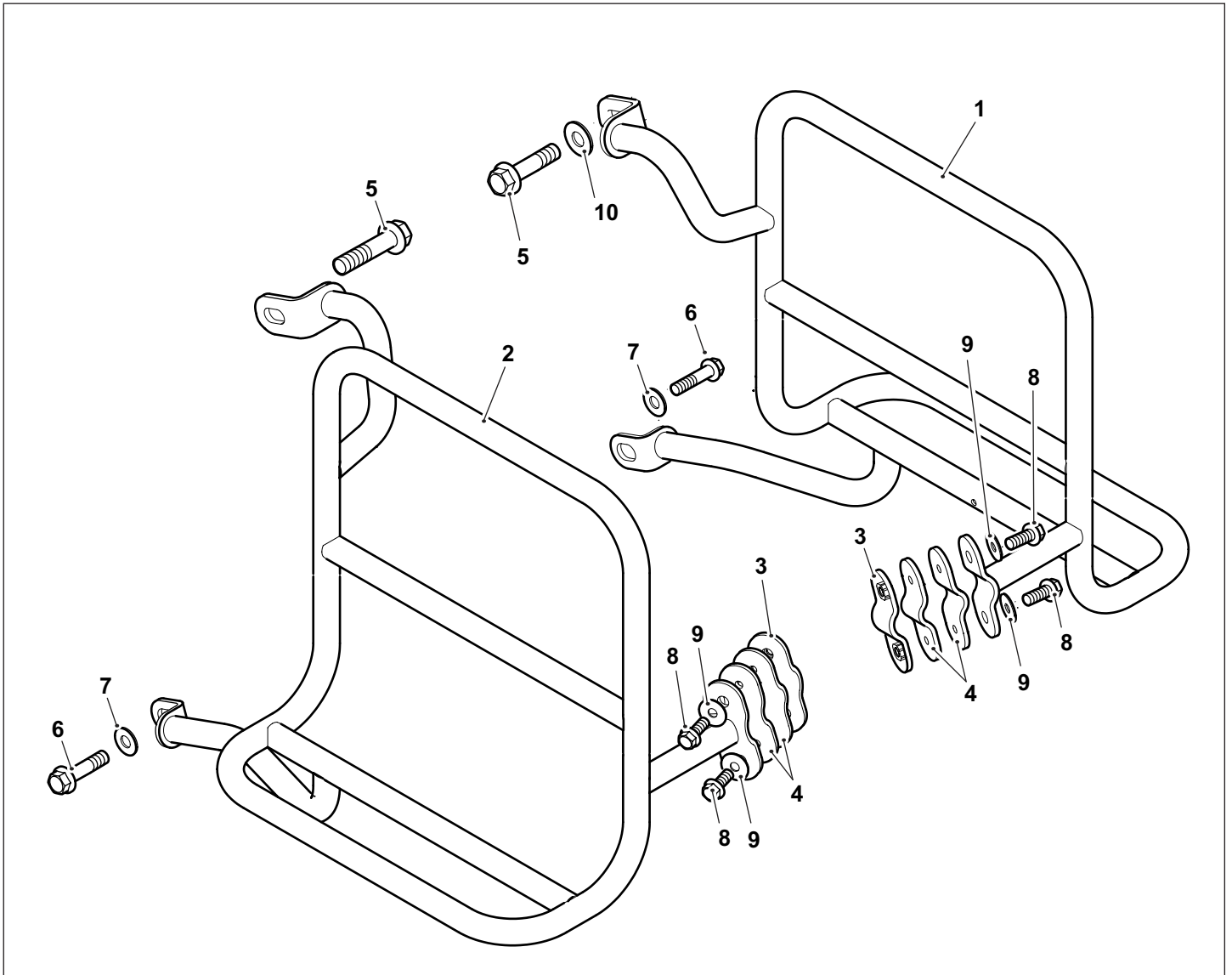

Item	Description	Qty
1	Pannier mount, right hand	1
2	Pannier mount, left hand	1
3	Pannier mount clamp	2
4	EPDM spacer	4
5	Fixing, 3/8 BSF x 55 mm	2
6	Fixing, M8 x 45 mm	2
7	Washer, M8	2
8	Fixing, M6 x 25 mm	4
9	Washer, M6	4
10	Spacer	1

1990638, 1990671 Pannier Mount Kit - Right Hand

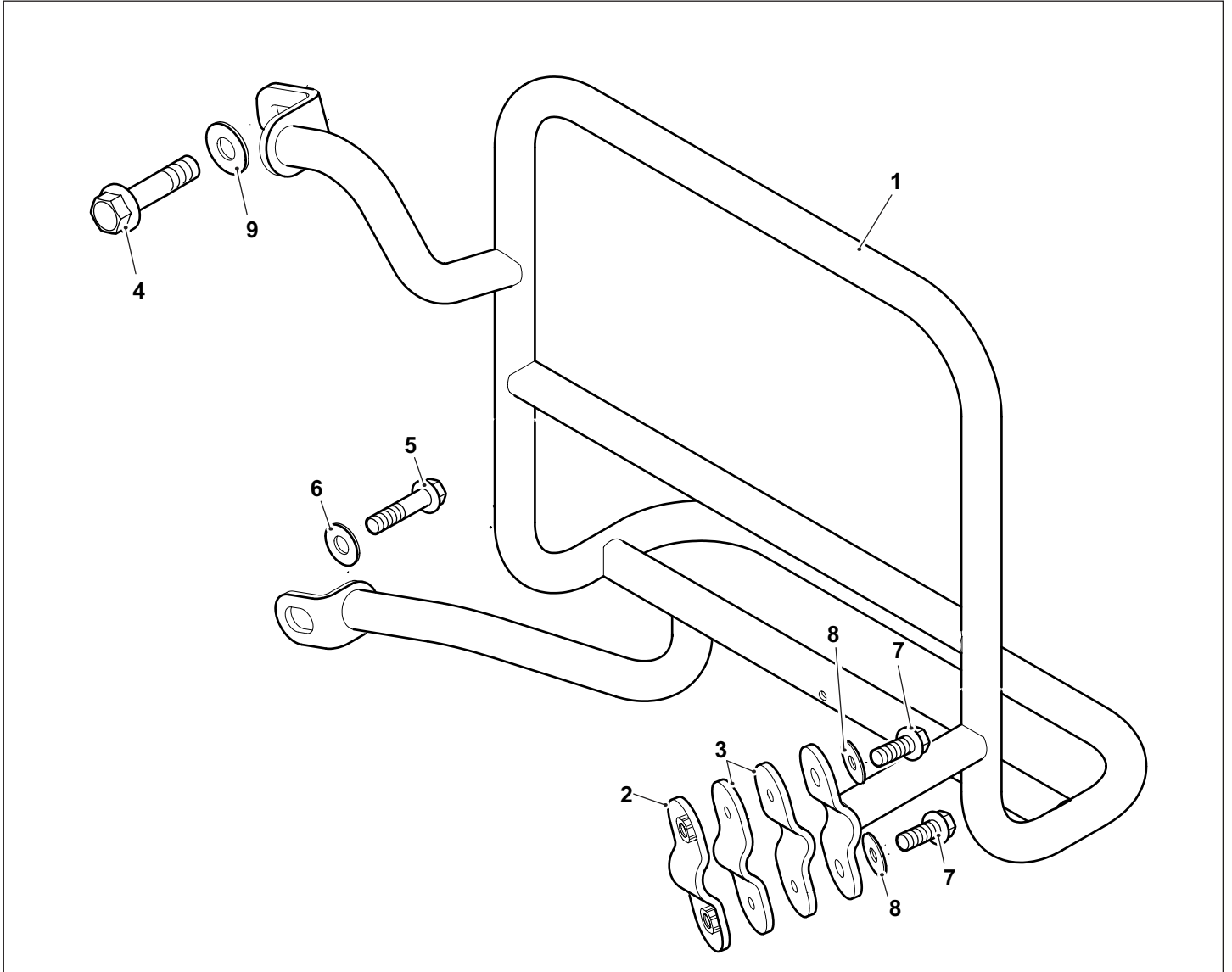

Item	Description	Qty
1	Pannier mount, right hand	1
2	Pannier mount clamp	1
3	EPDM spacer	2
4	Fixing, 3/8 BSF x 55 mm	1
5	Fixing, M8 x 45 mm	1
6	Washer, M8	1
7	Fixing, M6 x 25 mm	2
8	Washer, M6	2
9	Spacer	1

1990618, 1990619, 1990646 Pannier Kit - Pair

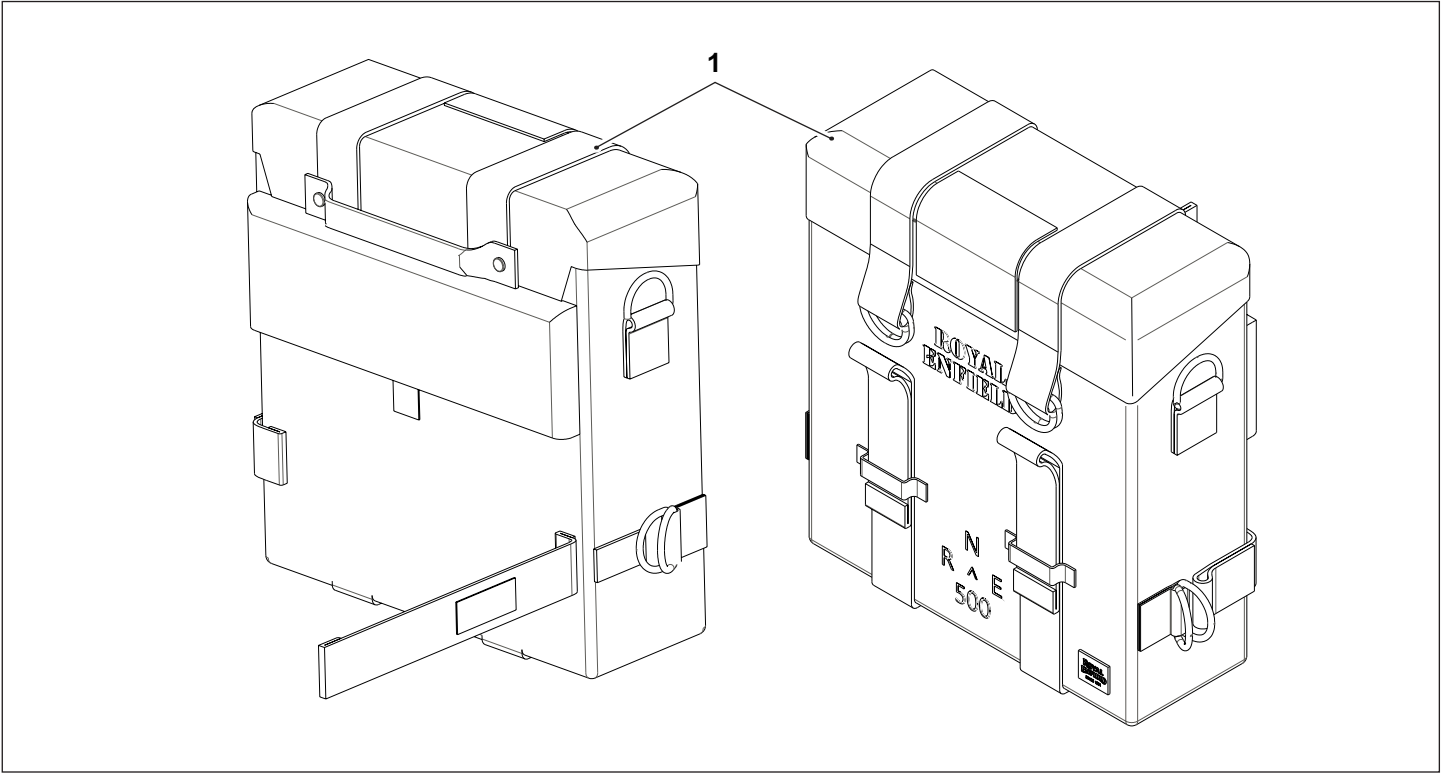

Item	Description	Qty
1	Pannier	2

1990654, 1990655 Pannier Kit - Right Hand

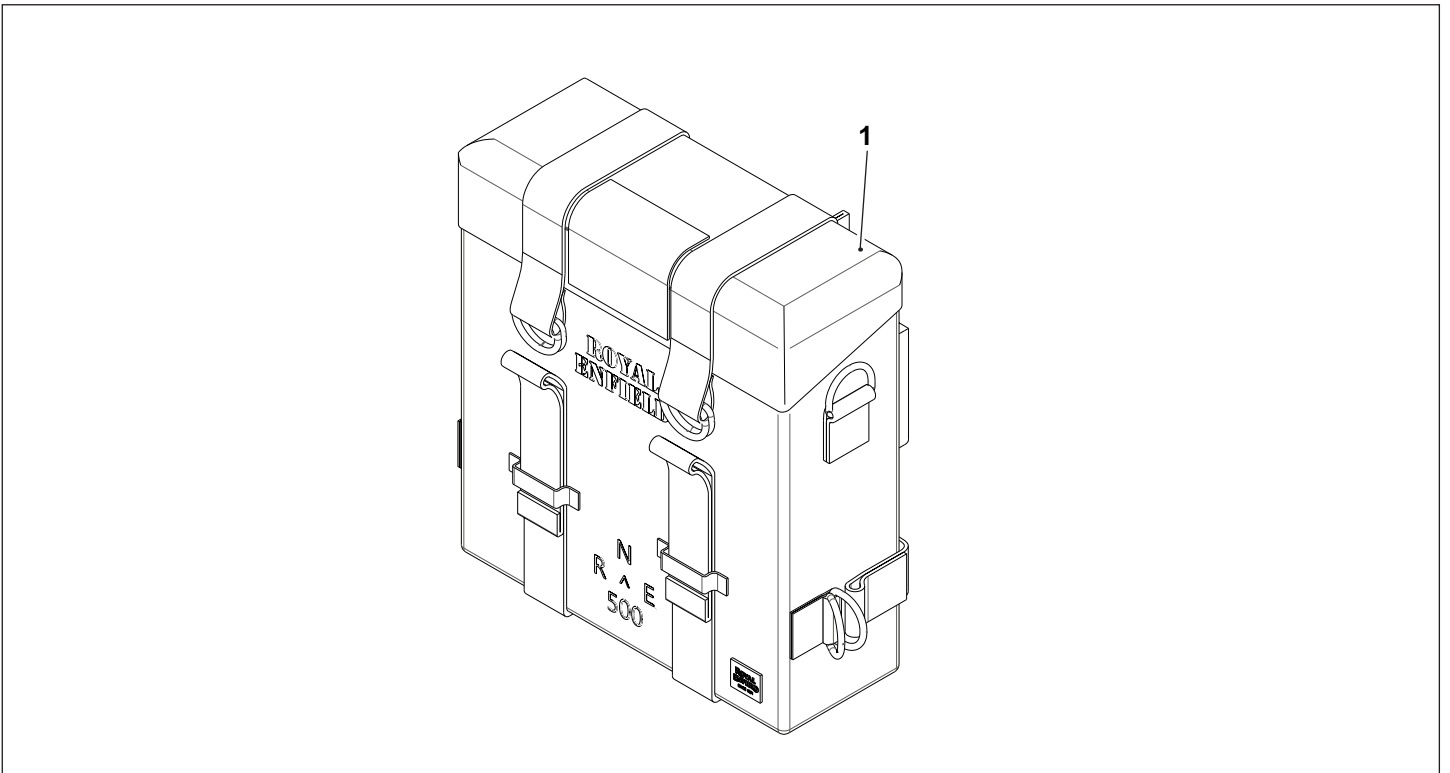

Item	Description	Qty
1	Pannier	1

Installing the Pannier Mounts

NOTE: The motorcycle may be fitted with a passenger seat, accessory luggage rack or rider seat only. The basic principle to fit the accessory pannier mounts is the same for all conditions. The illustrations show an installation where a passenger seat is fitted, however, any specific differences are highlighted clearly in the following instructions.

1 Where applicable, remove the passenger seat or luggage rack front fixings (1). Retain the fixings for reuse.

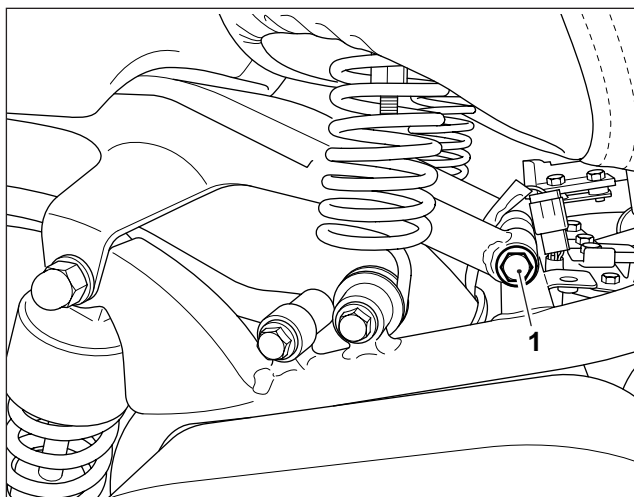

2 Remove the upper rear suspension retaining nuts (1) and washer/s (2) from the right hand and left hand side of the motorcycle, right hand side shown. Retain the nuts and washers for reuse.

NOTE: Motorcycles fitted with a passenger seat or luggage rack will have one washer, motorcycles without a passenger seat or luggage rack will have two washers.

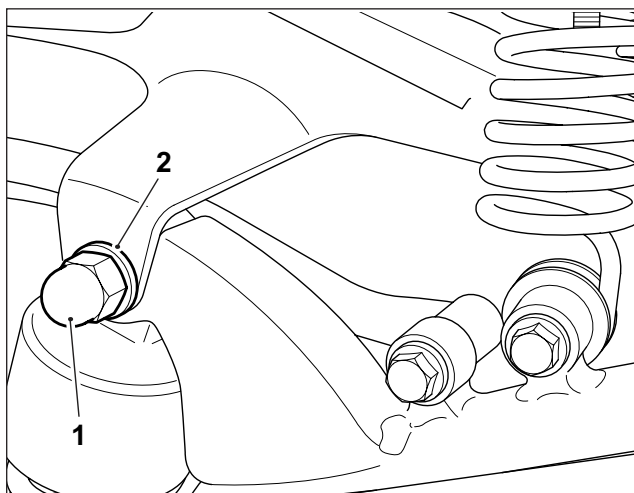

3 Remove the passenger seat or luggage rack, retain the passenger seat or luggage rack for reuse.

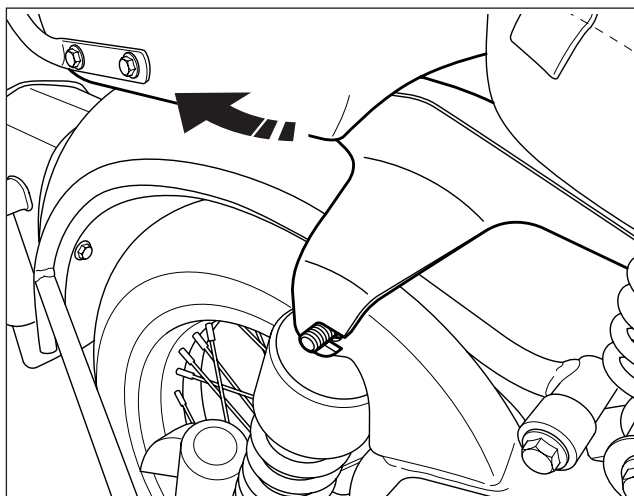

4 Remove the rear mudguard stay lower fixings (1) on the right hand and left hand side of the motorcycle, right hand side shown. Retain the nuts (2) for reuse, retain the fixings (1) for future reuse if the pannier mounts are to be removed.

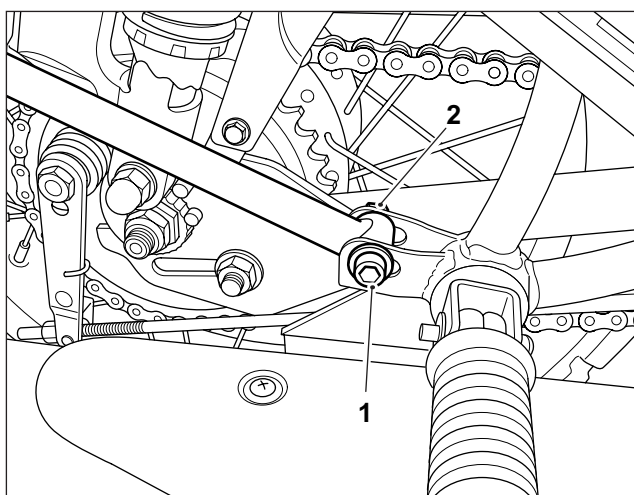

5 Loosen the rear mudguard upper fixings (1) on the right hand and left hand side of the motorcycle, right hand side shown. Do not remove the fixings.

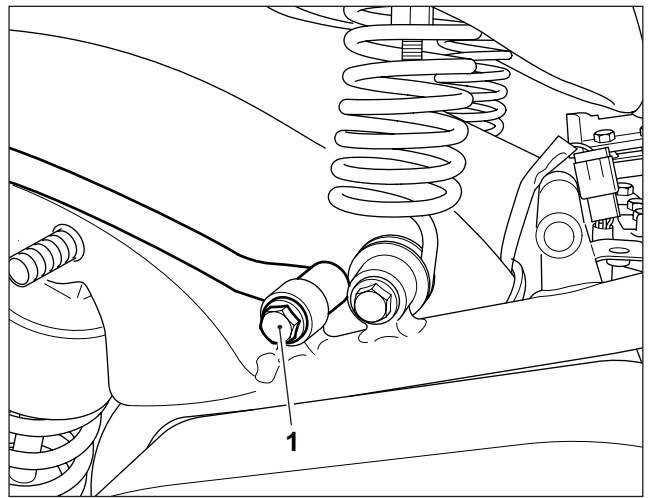

6 Carefully raise the rear mudguard (1), just enough to allow removal of the upper rear suspension fixings (2). Remove the right hand side and left hand side suspension fixings (2), right hand side shown. Retain the washers (3) for reuse, retain the fixings (2) for future reuse if the pannier mounts are to be removed.

NOTE: If fitting a right hand pannier mount only it is not necessary to remove the left hand side fixing.

CAUTION: Care should be taken when lifting the rear mudguard. Lift only enough to clear the rear suspension fixings. Lifting the rear mudguard too far may put strain on the electrical harness which could result in damage to the harness and equipment malfunction.

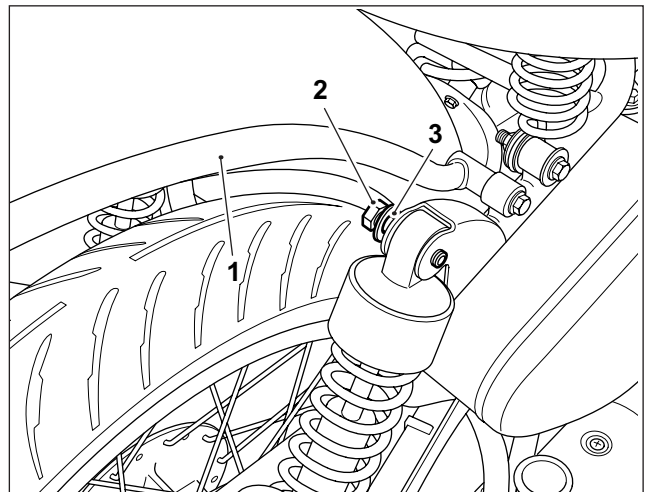

7 Fit the 3/8 BSF x 55 mm fixings (1) from the kit with the original washer/s (2) to the rear suspension upper mount/s, right hand side shown

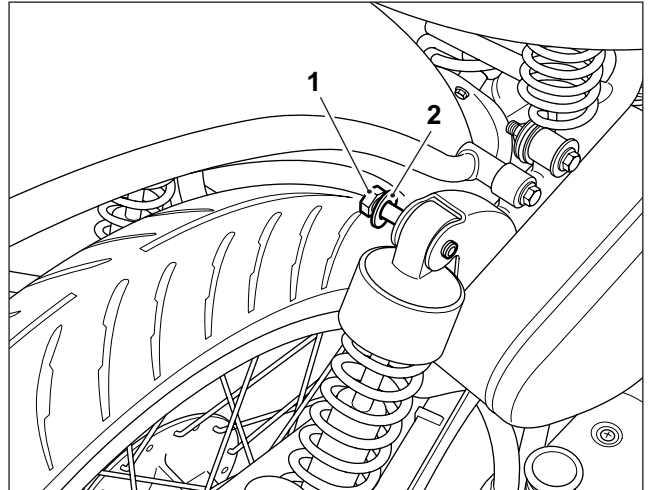

8 Ensure the lift handle (1) on the left hand side of the motorcycle is positioned on the fixing (2). Where a passenger seat (3), as shown, or a luggage rack is fitted they must be located behind the lift handle as shown.

If there is no passenger seat or luggage rack fitted the lift handle should be positioned behind the pannier mount.

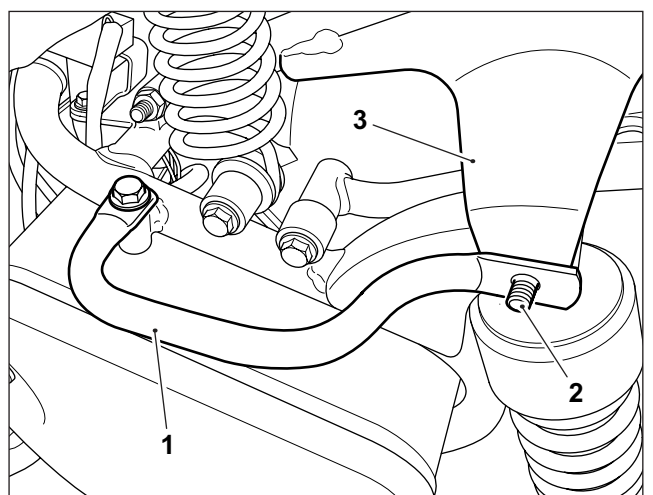

9 Carefully lower the mudguard into position.

10 Where applicable refit the passenger seat (1) or luggage rack ensuring it locates correctly on the rear suspension fixings (2), right hand side shown. Refit the original front fixings (3) and tighten the fixings to **25 Nm**.

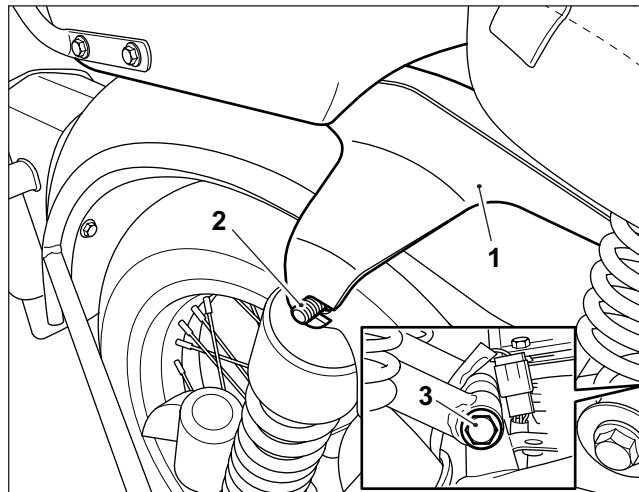

11 Motorcycles fitted with a passenger seat or luggage rack.

Position the right hand pannier mount (1) on the rear suspension upper mount fixing. Fit the original nut (2) and washer (3). Do not fully tighten the nut at this stage.

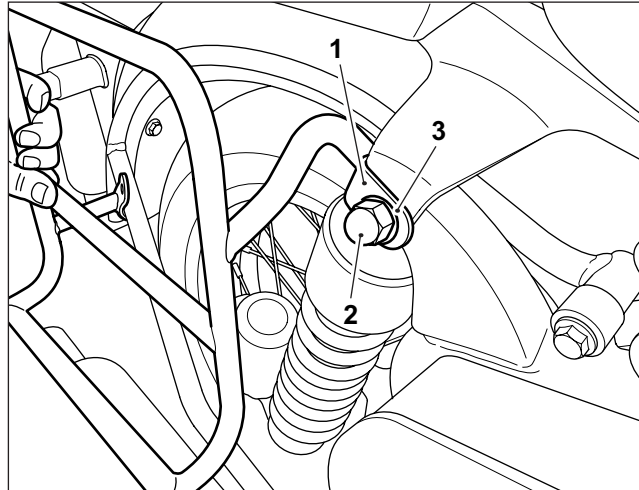

12 Motorcycles without a passenger seat or luggage rack.

Position the right hand pannier mount (1) on the rear suspension upper mount fixing (2). Fit the original nut (3) and washers (4) together with the spacer (5) provided in the kit, as shown. Do not fully tighten the nut at this stage.

NOTE: The spacer provided in the kit is only fitted to the right hand side of the motorcycle.

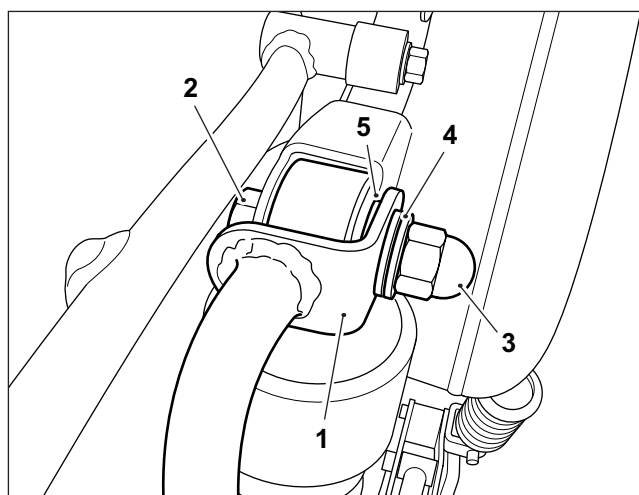

13 Align the lower pannier mount fixing (1) with the rear mudguard stay lower fixing position (2). Loosely fit the M8 x 45 mm fixing (3) and M8 washer (4) provided in the kit with the original nut (5).

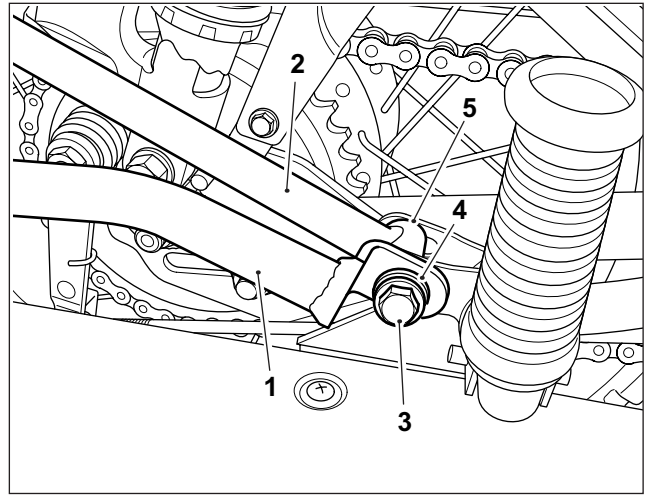

14 Align the rear pannier mounting (1) on the mudguard stay (2). Fit an EPDM spacer (3) from the kit between the pannier mounting clamp (1) and mudguard stay (2).

Fit the pannier mount clamp (4) with an EPDM spacer (3) from the kit between the pannier mounting and mudguard stay and loosely fit the M6 x 25 mm fixings (5) and M6 washers (6) from the kit.

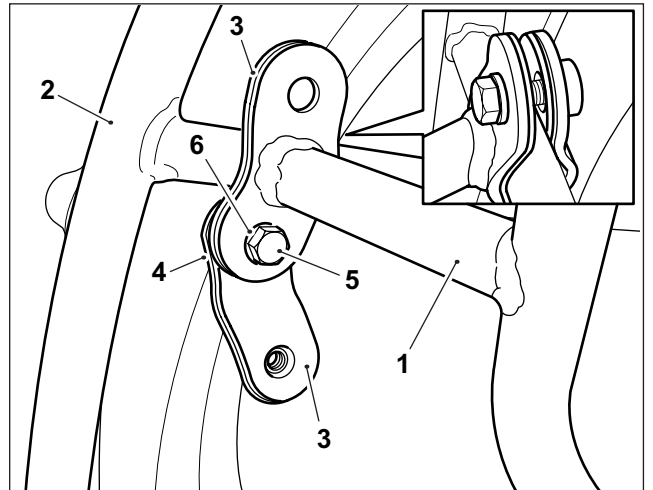

15 Ensure the pannier mount is aligned correctly and tighten;
The rear suspension upper fixing (1) to **40Nm**.
The rear mudguard stay fixings to (2) **30Nm**.
The pannier mount clamp fixings (3) to **5Nm**.

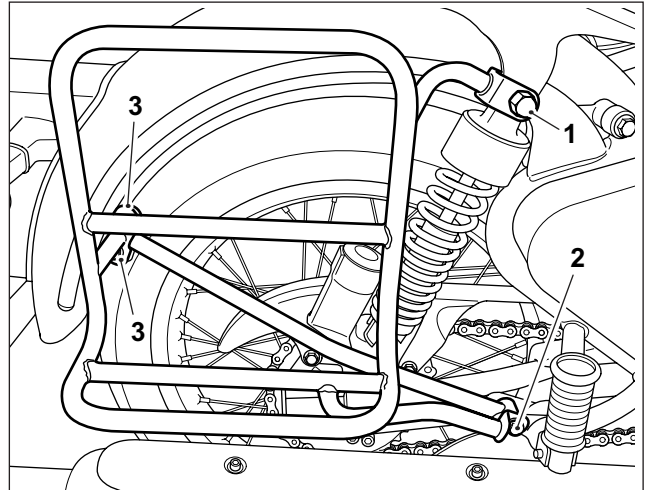

16 Tighten the rear mudguard upper fixing to **30Nm**.

Repeat steps 11 to 16 for the left hand pannier mount.

NOTE: The spacer provided in the kit is only fitted to the right hand side of the motorcycle and is not required for the left hand side due to the location of the lift handle.

Installing the Panniers

1 Collect one of the panniers from the kit. Open the pannier and fold out the internal side support panels (1) and fold down the base panel (2).

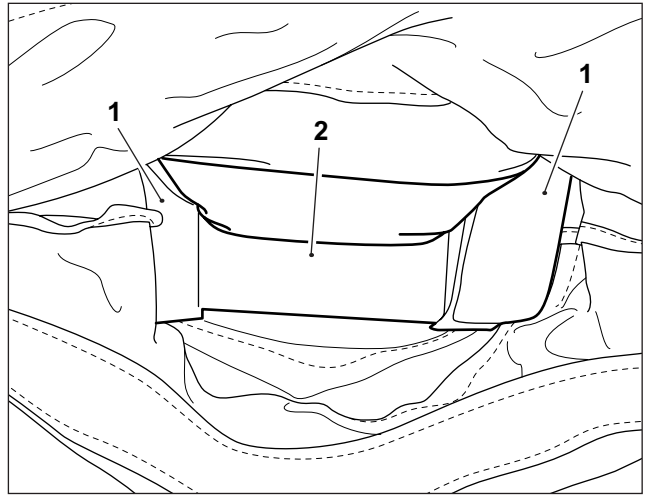

2 Release the hook and loop sections (1) to open the pocket (2) on the rear of the pannier.

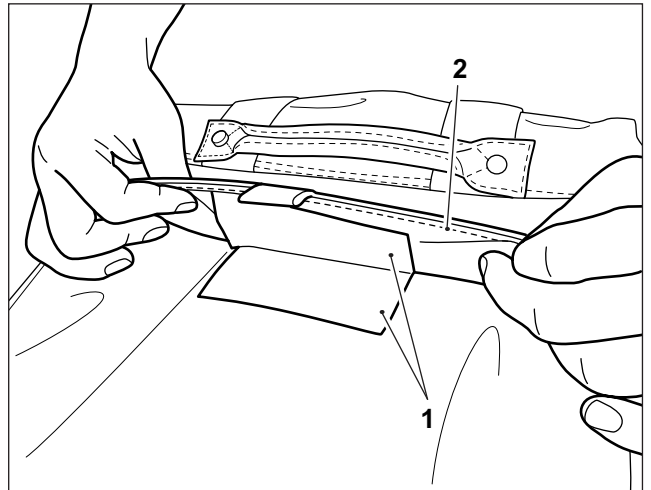

3 Fit the pocket on the rear of the pannier (1) over the top of the pannier mount (2) and pull the pannier onto the pannier mount as far as possible.

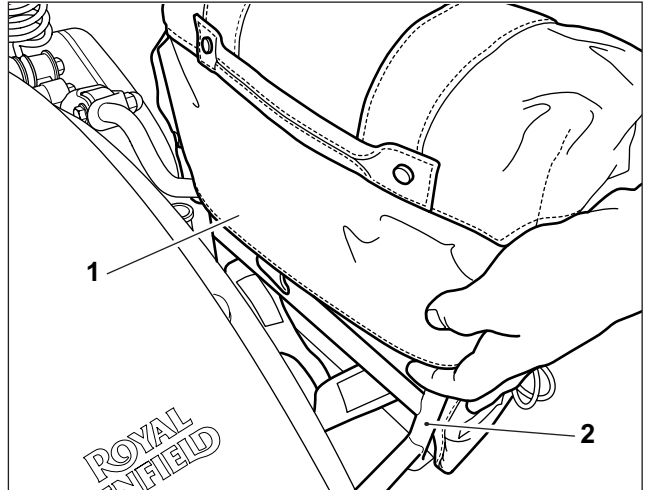

4 Feed the pannier rear retaining strap (1) under the pannier mount (2), as shown.

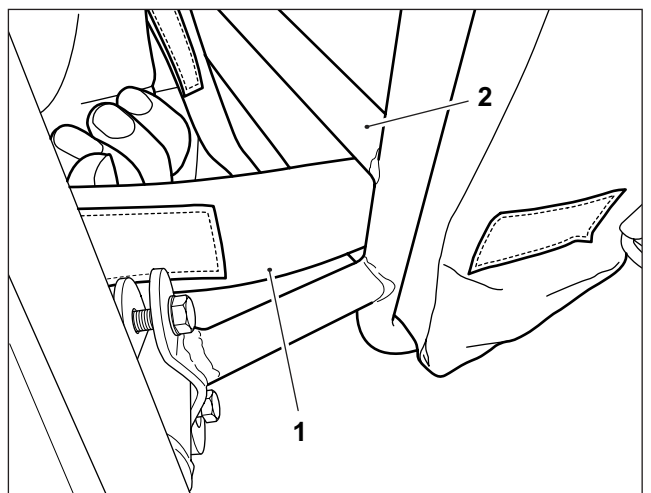

⚠ WARNING: If the pannier retaining straps are not positioned under the pannier mount as shown, the pannier will not be correctly secured to the motorcycle. Riding a motorcycle with insecure panniers fitted may cause the motorcycle to become unstable and result in an accident

5 Pull the retaining strap (1) around the pannier mount (2) and attach the hook and loop section of the strap (3) to the pannier (4).

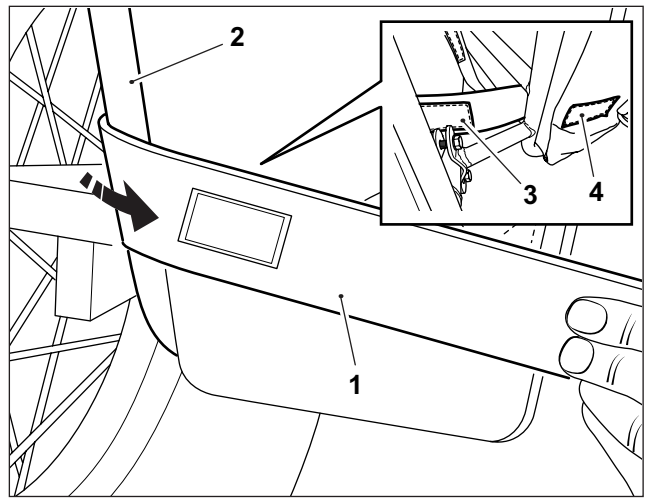

6 Feed the strap (1) through both D rings (2 and 3) on the pannier. Fold the strap (1) back over the front D ring (2) through the rear D ring (3) and pull tight.

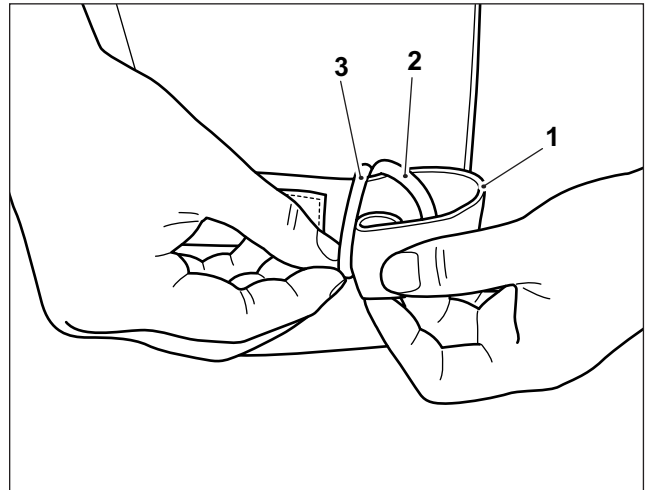

7 Attach the hook and loop sections of the strap together as shown. Repeat steps 1 to 7 for the pannier front retaining strap.

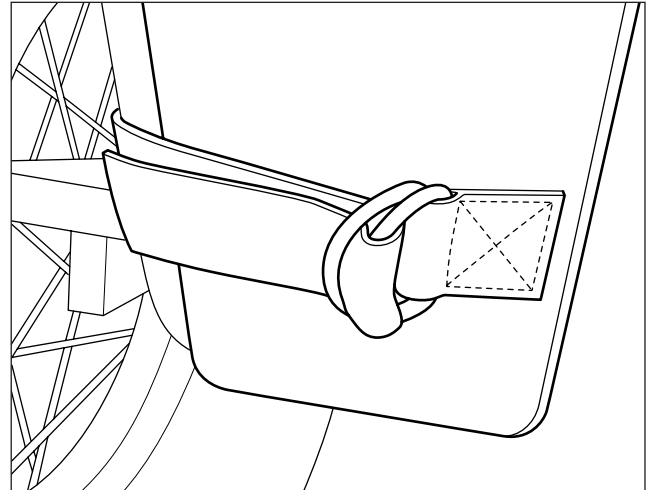

Using the Panniers

1 The panniers incorporate a shower proof lining to help protect any contents.
With the pannier lid open, holding the retaining clasps, pull the shower proof lining (1) up and taught to form a straight edge at the top.

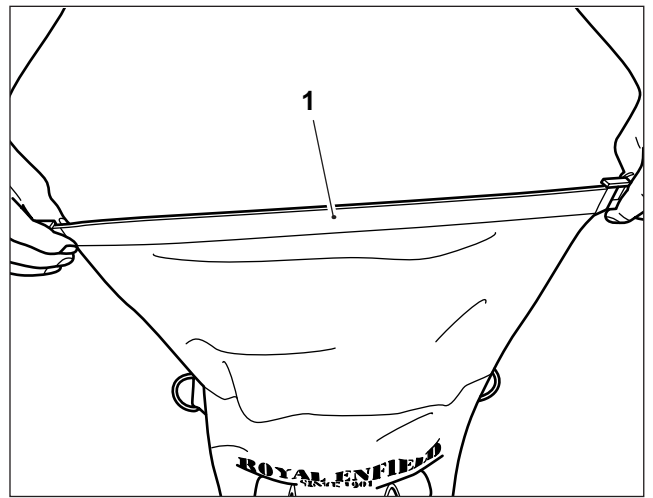

2 Fold over the shower proof lining (1) repeatedly to take up any excess lining and attach the retaining clips (2) to hold in position, as shown.

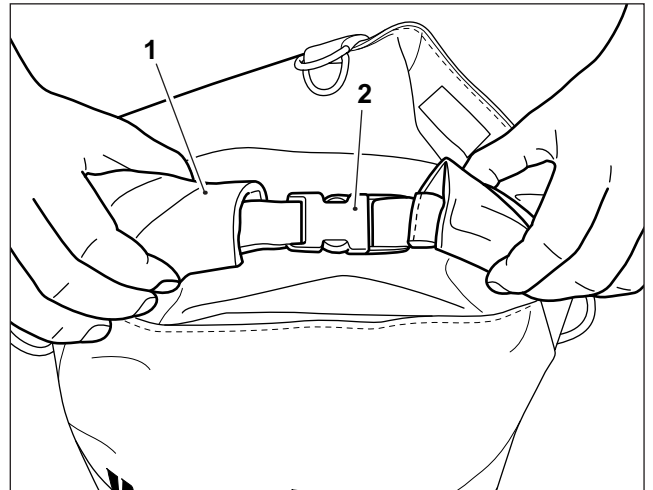

3 Close the pannier lid and secure one of the pannier lid retaining straps (1) through the D rings (2 and 3) on the front of the pannier as shown. Fold the strap (1) back over the upper D ring (2) through the lower D ring (3) and pull tight. Repeat for the second retaining strap.
Ensure the end of the straps (1) are correctly located through the retaining loops (4) on the pannier.

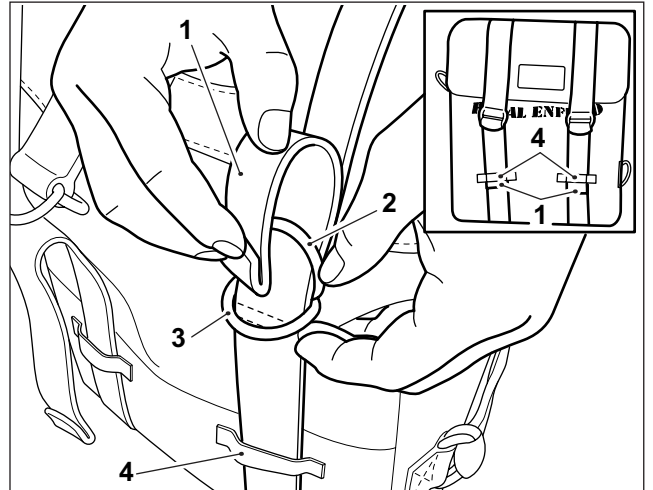

WARNING: Before riding a motorcycle fitted with accessory panniers always check that the panniers are securely attached to the pannier rails. Riding a motorcycle with insecure panniers fitted may cause the motorcycle to become unstable and result in an accident.

WARNING: Never overload the panniers, the maximum safe load for each pannier is 5 Kg. (11 lbs.). Incorrect loading of the panniers could cause the motorcycle to become unstable and result in an accident.

WARNING: The fitment of panniers to the motorcycle will affect the stability and handling of the motorcycle. Failure to observe the changes in motorcycle stability and handling characteristics could result in an accident.